

# A Simple Deviation Meter

James Brett G0TFP explains how he constructed a "simple", "practical" and "economical" deviation meter to check the deviation of an f.m. transmitter. Read on and discover just how easy it is.

The object in the design of this deviation meter was to build a self-contained piece of test gear which didn't require special calibration or additional test equipment. Construction was to be simple and practical and the cost was to be kept to a minimum hence the 'local oscillator' required is another transmitter on the same band.

The principle is to use two transmitters - the first one to be tested and a second one to be used as a local oscillator. This second transmitter doesn't have to be f.m. since it only has to produce a carrier at the same frequency as the signal on test.

By modulating the test transmitter with an audio tone and mixing the two transmitter outputs, a signal results which is purely the frequency deviation. This deviation is converted to a voltage proportional to the highest frequency and thus indicates the peak deviation occurring at the peak amplitude of the audio modulation.

Calibration is easily carried out by having both transmitters on c.w. and setting one to a different known frequency.

## The Circuit

The circuit is straightforward and signals from the transmitter to be tested and the transmitter which is to act as the local oscillator are fed into the two banks of load resistors R1 to R6. (See Fig. 1). These resistors have the resistive elements cut as a spiral on the carbon film surface and by winding the three turns around one resistor in each bank the two signals are

into the frequency to voltage converter integrated circuit IC1. The circuit being used and biased as described in the manufacturers instructions.

The relationship between the input frequency and the output voltage on pin 10 is set by the combination of C6 and the total resistance of R15 plus that set on R17. Capacitor C7 is made comparatively large and since the circuit works on the charge 'pump' principle, it provides integration of the signal to be fed to the output. The resulting effect is a quick response to an increasing frequency but a slow decay following a reduction of input frequency.

Since the transmitter under test is being modulated with an audio sine wave, the output of the circuit will respond quickly to the positive peak of the deviation and will not fall before the next positive peak of deviation.

The output circuit of IC1 is a buffering amplifier and setting it to unity gain by linking pin 10 to 5, it is able to drive the dual range voltmeter circuit M1, R18 and R19.

An audio tone of approximately 400Hz for the transmitter is generated by IC2 which is a conventional Wien bridge oscillator. With C8 equal to C9, R21 equal to R21 the frequency is determined by the formula:

$$f = \frac{1}{2 \cdot C_8 \times R_{21}} \text{ Hz}$$

For sinusoidal output, the circuit must not become over

Fig. 1: Full circuit diagram of James G0TFP's "simple" Deviation Meter.

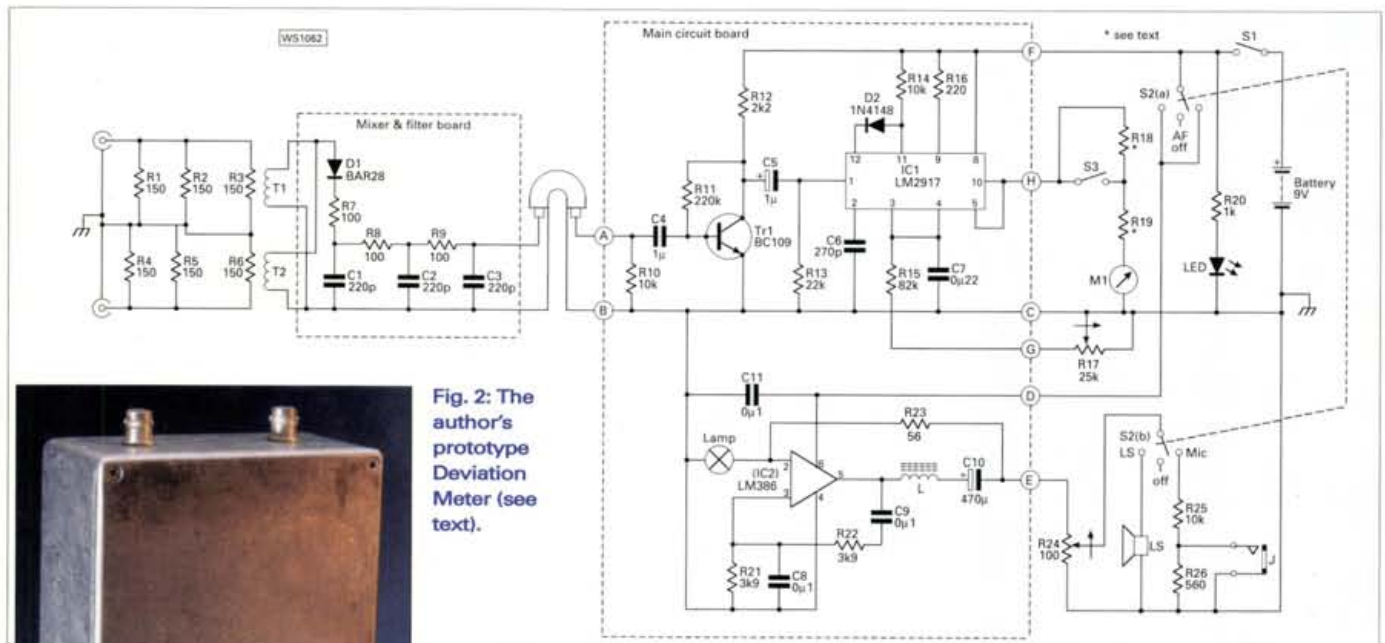

Fig. 2: The author's prototype Deviation Meter (see text).



coupled to the diode mixer, D1.

Both transmitters are set to the same frequency and with one of them modulated, one of the outputs from the mixer is the deviation frequency caused by the audio modulation.

Resistors R7 to R9 and the capacitors C1-C3 form a low pass filter which, at a few kilohertz gives negligible attenuation, but at v.h.f. virtually eliminates all the carrier and sum frequencies. This low frequency signal is passed to the base of Tr1 and is large enough to give a comparatively square wave output on its collector. This square wave is fed by C5

driven and needs to have a loop gain of three. This is set by the feedback circuit R23 and the lamp. As the output starts to rise, more voltage appears across the lamp and the filament gets hotter, increasing its resistance. This increases the proportion of the output fed back and reduces the overall loop gain, thereby keeping the output constant.

The circuit can easily become unstable and the ferrite bead with two turns of wire provides enough loss to completely prevent IC2 self oscillating at some very high random frequency.

As IC2 is a low power audio amplifier it's able to drive a loud speaker directly via the d.c. blocking capacitor, C10. The test transmitter microphone is placed over the loud speaker to provide the modulation. Alternatively, S2 can isolate the speaker and through the attenuation of R23 and R24, can give a signal

suitable for direct connection to the transmitter microphone input. The level in either case is set by R24.

### Choice Of Meter

The choice of meter, M1, is not critical, any value of moving coil ammeter between 50µA and 5mA will do. For ease of remarking, a scale of 5 or 2.5 main divisions would be best.

Also, to give an accurate range between 5kHz and 25kHz, R18 should be four times the total resistance of R19 plus the resistance of the meter coil. The total resistance of the full combination of R18, R19 and the meter coil resistance should be chosen using Ohms law to give approximately 4.5V across the network for full scale deflection current of the meter.

(The full scale voltage of this circuit is not critical since the calibration is made in terms of deviation frequency using R17 as will be described later).

### Suggested Layout

Suggested layouts are shown in Fig. 4 and Fig. 5 and the wiring of the panel components is taken from the full circuit diagram in Fig. 1.

The two banks of load resistors, R1 to R6, are mounted directly onto the coaxial plugs and the earth tabs keeping the leads as short as possible. One resistor in each bank is wound with three turns of plastic covered wire leaving long ends to be twisted and brought through the grommets holes to the mixer board.

Each resistor bank is screened using a thin aluminium sheet which is cut carefully to make a tight fit with the lid and bottom of the box. If a box with circuit board guides is used only with the joint between the dividing piece and the main screen needs to be fixed with nuts and bolts, the mixer board is wired and mounted on short pillars in the box.

The rest of the circuit and components are mounted on the lid and wired to the suggested layout in Fig. 5 to avoid the screened load compartments. The battery is fitted into a 25mm Terry type tool clip and held into place by an elastic band across the open ends of the clip.

If the speaker has no mounting lugs it can be held in place using three countersunk headed screws round the outer edge of the speaker and the edge of the speaker frame trapped by using large plain washers under the nuts (a matrix of holes having been drilled to let the sound out).

Since in use, the microphone of the transmitter under test will be placed directly over the speaker - a piece of thin foam should be placed over the matrix of holes or a ring of soft rubber glued round the circumference of holes. This is needed to prevent unwanted vibration or other hand induced noise affecting the sinusoidal sound and giving inaccurate results.

Once the components are all mounted and the interconnections between the components wired as far as possible a careful wire check should be made. Finally, the main circuit board is wired in with wire tails long enough to allow access to both sides of the circuit board and the panel components, the probable best position over the meter and speaker.

### Careful Inspection

After a final (careful) inspection and wire check, the battery is connected. Set R17 and R24 fully anticlockwise,

S3 open (25kHz position), S2 to mid position (a.f. off) and switch on S1. The l.e.d. should light up, showing that the power is on.

Set S2 to the LS position and advance R24. An audio note of approximately 400Hz should be heard. For the musically minded, this is approximately 'G' in the middle of the music scale.

The output of IC2 should be between 2 and 3V peak-to-peak. If an oscilloscope is not to hand, the level can be measured using a multi-range meter set to a.c. volts. Since this will read r.m.s., a

reading between 0.7 and 1V should be indicated. If the level is outside these limits, increase the value of R23 to reduce the amplitude or vice-versa.

Set S2 back to 'off' and connect two transmitters to the two coaxial inputs. Set S3 to the 25kHz position and both transmitters to the same frequency and output powers of a watt or so.

Switch on both transmitters and, although there may be a very slight meter movement, it should be basically at zero. Adjust one of the transmitters up or down 25kHz. The meter should now read and by adjusting R17 it can be made to read full scale of 25kHz.

If one of the transmitters can be set to smaller step changes, make the change and check that the meter now reads the set difference in frequency between the two. If a difference of 5kHz can be set, put S3 into the 5kHz position and check that the meter again reads full scale. The unit is now tested and calibrated for deviation measurements to be made.

### Application

The transmitter to be tested and the one to act as the local oscillator are connected and switched on at power levels of a watt or two. Calibration at 5 or 25kHz may be carried out as described above.

Set both transmitters to the same frequency and place the microphone, of the transmitter on test, over the loud speaker. With S2 in the LS position adjust R24 to give a sound level equivalent to speaking into a microphone. The meter will indicate the maximum deviation from the centre frequency of the transmitter. If the automatic gain of the audio amplifier in the transmitter is working correctly, quite substantial adjustment of R24 will only produce a small change in meter reading.

If it's not practical to apply the microphone directly to the loud speaker, a lead can be made up with a connector to mate up with the transmitter microphone socket. A switch will probably have to be included connected to the microphone connector to replace the p.t.t. switch.

As a typical guide, an amateur transmitter on narrow band f.m. (n.b.f.m.) should give a deviation as measured of 2.5kHz. The deviation meter can also prove useful in comparing differences in transmitter output frequencies or such things as v.f.o. calibration, etc.

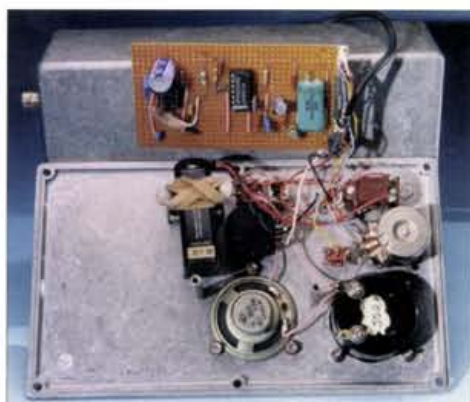

Fig. 3: An inside view of the unit showing method of construction using Veroboard (see text).



Fig. 4: Close up view of main board showing layout. (see text for details on layout).

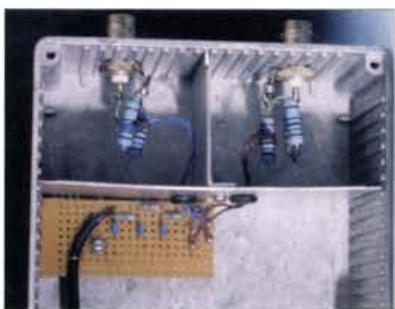

Fig. 5: Close up view of the two input ports and coupling method (see text).

### Constructional lay-out using Veroboard.

Readers wishing to build their own Deviation Meter using Veroboard rather than designing their own printed circuit board lay-out can obtain (free of charge) photocopies of the matrix board lay-out used by the author. To receive the photocopies please send an A5 self-addressed stamped (26p) envelope to the Editorial offices marked as **Deviation Meter Details**.

### Component List

#### Resistors Fixed

1W 10% Carbon Film  
150Ω R1-R6

0.25W 10% Carbon Film

56Ω	R23
100Ω	R7, R8, R9
220Ω	R16
560Ω	R26
1K	R20
2K2	R12
3K9	R21, R22
10K	R14, R25
22K	R13
82K	R15
220K	R11
See text	R18, R19

#### Resistors Variable

100Ω Wire wound	R24
25K Carbon	R17

#### Capacitors 15V d.c. or greater

220pF Ceramic 10%	C1, C2, C3
270pF Ceramic 10%	C6
0.1µF Poly 10%	C8, C9, C11
0.22µF	C7
1µF	C4
1µF Electrolytic	C5
470µ Electrolytic	C10

#### Semiconductors

BAR28	D1
1N918/1N4148	D2
BC108	Tr1
LM2917N	IC1
LM386	IC2

#### Miscellaneous

1.5V/25mA lamp (Tandy 272-1139), meter (see text), loud speaker - miniature 8Ω, two coaxial panel connectors with earth tags, mono jack socket, panel l.e.d., two SPST switches, DPDT centre off switch, 9V PP3 battery and snap connector, two metal box 110x190x55mm (approx) aluminium sheets for screen, knobs for variable resistors, wire, two small grommets, pillars, nuts and bolts.