

How to Build a Frequency Converter

Do you enjoy building simple projects that are useful? If so, you may wish to construct a frequency converter that can be used with an AM radio to provide coverage of one of the shortwave bands.

The AM radio we discussed in November *Monitoring Times* can be used with a converter to enable you to listen to the high frequencies.¹ The AM receiver is tuned across its range to provide reception of signals in the HF (high frequency) spectrum, while the converter oscillator remains fixed at the crystal frequency. A calibration scale may then be added to the dial of the AM receiver for logging your favorite shortwave frequencies.

How a Converter Operates

We may use tunable or fixed-tuned converters for covering frequencies beyond the range of our basic receiver. When we place a tunable converter ahead of our main receiver, the main receiver is tuned to a particular frequency that we do not change. The shortwave tuning is done at the converter. It has a tunable oscillator rather than a crystal-controlled one. Therefore, this converter must have its own tuning mechanism and dial.

Alternatively, we can use a crystal-controlled converter, which requires that we tune the shortwave band by changing the dial settings on the main receiver. In this instance the main receiver is called a "tunable IF (intermediate frequency)" system. The frequency to which the main receiver is tuned is the IF for the converter. In other words, if we use an AM broadcast receiver as a tunable IF, the converter's IF varies from 550 to 1600 kHz as we scan the 1050 kHz-wide AM band spectrum.

A variety of tunable IFs may be used with converters. For example, if you have a receiver that tunes, say, 2 to 4 MHz, the outboard converter can be tailored for use across that tuning range. It is not necessary that we use an AM broadcast radio.

A good example of this concept is seen when we recall the earlier days of TV reception when outboard UHF converters were used ahead of the VHF TV receivers to permit coverage of the standard UHF channels. Radio amateurs have for years used homemade and commercial VHF converters ahead of their HF receivers in order to receive VHF, UHF and microwave signals.

An AM Receiver as the System IF

Most transistorized AM broadcast receivers have a built-in ferrite loop antenna. This means that the radio will pick up broadcast band signals, even when an HF converter is used with the AM radio. This is an annoyance, and it will spoil reception of the HF signals. Something needs to be done to prevent the broadcast-band signals from being heard when we listen to shortwave stations.

I enclosed my AM receiver in a metal box, and connected an earth ground to the box. This prevents pickup of all but the loudest AM-band signals. Even the nearby local AM station signals are so weak that they do not cause interference to the shortwave signals that are provided by the converter. The main tuning, audio gain and on-off controls are relocated to the front panel of the metal cabinet for the sake of convenience.

It is an easy matter to shield the AM radio module that was shown photographically in my November 1988 *MT* article. If you have a different radio, simply remove the circuit board from the plastic cabinet and install it in a metal case as described in the foregoing text. The circuit modifications suggested in the previous article are recommended if you plan to use a converter with your transistor radio. The small link that is wound on the ferrite loop will serve as your coupling circuit to an outboard converter. This link may be routed to a phono or coaxial jack on the rear of the metal cabinet.

Unfortunately, AM broadcast-band radios do not contain a BFO (beat frequency oscillator). This circuit is necessary for the reception of CW (continuous wave) and SSB (single sideband). Without a BFO the CW signals appear as dull thumping sounds in the receiver. SSB signals sound garbled and you cannot understand what the operator is saying.

A BFO provides a beat note for CW reception when its signal is beat against the incoming CW signal. This provides an audible tone in the speaker. The tone results from the difference between the CW signal and that of the BFO -- usually 400 to 1000 Hz offset, depending upon how you tune in the CW signal. For SSB reception, the BFO supplies the missing SSB carrier to allow a near equivalent to AM signal reception.

Most transistor AM receivers use a 455-kHz IF. Therefore, should you desire to add a BFO, you can build a one-transistor 455-kHz oscillator and feed its output signal to the diode detector in the AM radio. The BFO energy is applied between the detector diode and the last IF transformer of the AM radio. See Figure 1 for a suggested circuit. The upper part of the circuit diagram shows the last IF amplifier and AM detector in a typical AM transistor radio. Note that the 56-pf coupling capacitor from the BFO is attached between D1 and the secondary winding of the IF transformer.

The BFO in Figure 1 is a tunable type. A 455-kHz IF transformer may be taken from a discarded AM receiver and used for T1. The smaller winding (1 & 2) is used for feedback in order to make the 2N3904 oscillate. If your BFO does not oscillate, reverse the T1 leads marked 1 and 2. Oscillation will not occur unless the phasing of the two windings is correct for obtaining positive feedback. Tune T1 for the proper

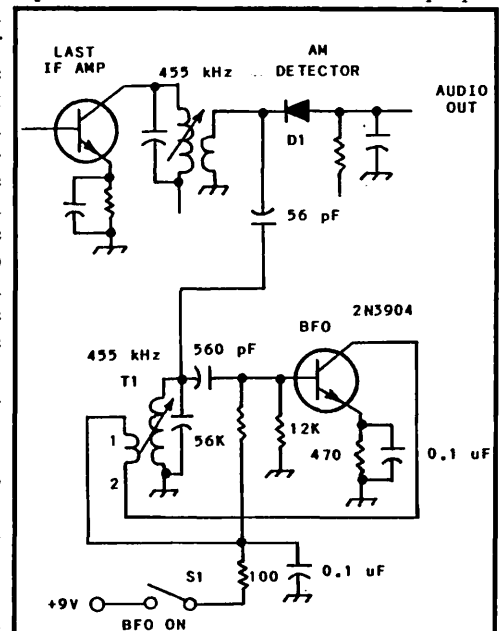

Fig. 1 -- Circuit for the last IF and diode detector of an AM broadcast-band radio to illustrate how the homemade BFO in the lower part of the drawing is connected to the detector. T1 is a standard 455-kHz IF transformer from a transistor AM receiver. A variety of NPN transistors can be used for the BFO, such as the popular 2N2222.

audio quality when listening to an SSB signal, after first tuning in the SSB signal for maximum strength. This setting will also permit CW reception.

A Converter for 7 TO 8 MHz

The range from 7 to 8 MHz will enable you to hear Amateur radio signals (CW and SSB), Radio Moscow, the Canadian time station (CHU) and a host of other foreign and domestic broadcasts. I chose this range mainly to acquaint you with BFO use for CW and SSB, since most shortwave broadcasts are done in the AM mode. The 40-meter ham band will contain CW and SSB transmissions.

Figure 2 shows the circuit for our simple shortwave converter. A dual-gate MOSFET is used as the mixer. T1 is tuned to 7.5 MHz for peak signal strength. T2, the IF transformer, is tuned for the center of the AM-Radio tuning range. A resistor is shown across the T2 primary winding. It is used to lower the tuned-circuit Q in order to broaden the response of the IF transformer. The lower the resistance value the greater the bandwidth, but the lower the converter gain. Experiment with this

resistor value to obtain the results you want. Values between 2.2K and 10K are normally used for this part of the circuit. The output of T2 (secondary) is connected to the input link on the AM-radio loop antenna.

Q2 is a JFET (junction field-effect transistor). It operates as a crystal-controlled oscillator at 8550 kHz. This frequency minus 7000 kHz equals 1550 kHz, and 8550 minus 8000 kHz equals 550 kHz, the tunable IF range of the AM receiver. Output from Q2 is injected on gate 2 of the Q1 mixer. The Q2 signal, when mixed in Q1 with the incoming 7-8 MHz signal, provides the IF of 550-1550 kHz at the output of Q1.

Construction

You may build the Figure 1 and 2 circuits on perforated board. Keep all signal leads short and direct in the interest of good performance. If you're experienced with circuit-board layout and fabrication you may prefer to build your BFO and converter on a PC board. Surplus computer crystals are available in frequencies close to 8550 kHz. You may wish to use one of these low-cost crystals if they are reasonably close

to the desired 8550 kHz frequency. A corresponding change in the tunable IF versus received frequency will occur when you use a crystal that is offset from 8550 kHz.

Final Remarks

The purpose of this article is to familiarize you with converters and how they operate. I urge you to tackle this project as a learning exercise. You may wish to alter the constants for T1 of Figure 2, plus the Q2 crystal frequency, to permit reception of other portions of the HF shortwave spectrum. No other circuit changes are necessary. The converter in Figure 2 represents, perhaps, the simplest circuit that can provide acceptable performance. I chose it over an elaborate, high-performance converter in order to keep this project simple and to the point.



References

- 1 DeMaw, "Improving AM Transistor Radio Performance," *Monitoring Times*, November 1988, page 92.

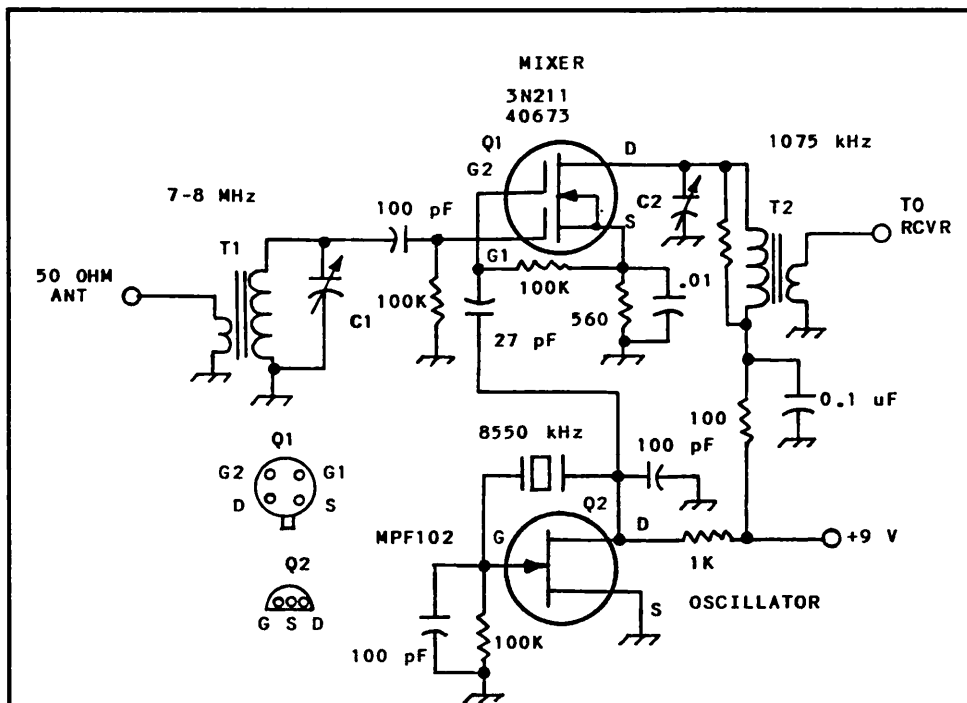

Fig. 2 -- Schematic diagram of a practical shortwave converter for use with a broadcast band AM radio to permit reception from 7 to 8 MHz. C1 is a 100-pf ceramic or mica trimmer. C2 is a 300-pf mica trimmer. T1 has two turns of no. 26 enamel wire on the primary and the 6-uH secondary has 33 turns of no. 26 enamel wire on an Amidon Assoc. T68-2 powdered-iron toroid. T2 has an 80 uH primary winding. Use 34 turns of no. 28 enamel wire on an Amidon Assoc. FT-50-61 ferrite core (125 mu). The T2 secondary has 5 turns of no. 28 enamel wire. (Amidon IAssoc., 12033 Otsego St., N. Hollywood, CA 91607). All fixed capacitors are disc ceramic and resistors are 1/4 watt carbon composition.



Dick Smith
is alive
and well
in Indiana

and the new
MARCH '89 CATALOG
is NOW AVAILABLE!

The Dick Smith Electronics Catalog is the fun way to find the electronic things you need. And the March Catalog is bigger - 176 pages crammed full of the things the other guys don't offer - and better - with more of our exclusive data pages including the new "feed back" section that invites your participation. And now the Catalog is as dynamic as Dick himself with a new issue each month to keep you up-to-date in the fast-paced world of electronics. Join the fun! Send us your name, address, and \$2 for your new March '89 Catalog today!

LINDA CARTER, Catalog Subscriptions
P.O. BOX 488, GREENWOOD, IN 46142
Phone 317-888-7265 - Fax 317-888-7368

