

RCA

Ham Tips

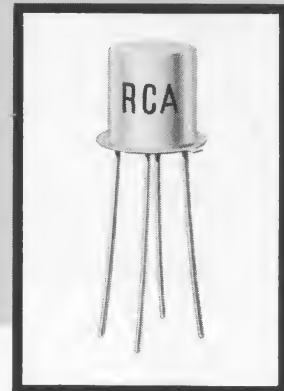

VOL. 28, NO. 4

DECEMBER, 1968

A Single-Gate MOS-FET Preamplifier For the 2-Meter Band

By R. M. Mendelson, W2OKO

RCA Electronic Components*

RCA MOS insulated-gate field-effect transistors are N-channel, depletion-type silicon devices, and are available in both single-gate and dual-gate types. Both types offer the advantages of extremely high input resistance, low input capacitance, very low feedback capacitance, high forward transconductance, and low noise at very high frequencies. Because of their insulated-gate construction, these devices have extremely low leakage currents which are relatively insensitive to temperature variations. In addition, their drain currents have a negative temperature coefficient which makes "thermal runaway" virtually impossible.

In the preceding issue of "Ham Tips" (November, 1968), Authors D. W. Nelson, WB2EGZ, and G. E. Yewdall, W2DMR, discussed the use of a dual-gate device in the construction of an MOS-FET preamplifier for the 10-meter band. R. M. Mendelson, W2OKO, now offers the radio amateur a choice of two single-gate types, either of which may be successfully employed for construction of an MOS-FET preamplifier affording excellent coverage of the 2-meter band.

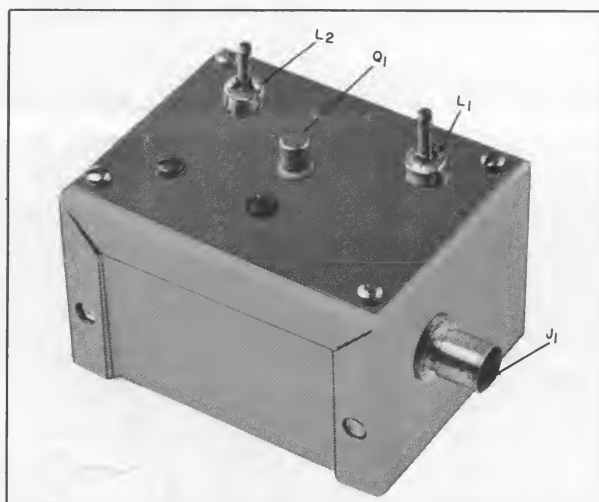

Figure 1: Exterior view of W2OKO preamplifier shows how brass-plate chassis is mounted on top of the minibox. Call-outs indicate locations of the two tuning capacitors, the MOS field-effect transistor, and the coaxial jack.

The major disadvantage of bipolar transistorized RF amplifiers is their poor cross-modulation characteristics; an otherwise excellent, high-gain, low-noise amplifier can be useless in a reception area with strong local signals. Today, this handicap can be easily overcome by utilizing the superior performance qualities of the RCA metal-oxide-semiconductor (MOS) field-effect transistor. For example, two single-gate types—the RCA-3N128 and RCA-40467A—demonstrate (at maximum gain) cross-modulation characteristics equal to or better than those of the best vacuum tubes. Because these types have noise figures in the order of 3.5 dB at 200 MHz, they are ideal for 2-meter operation. Their small size, instant startup, excellent reliability, and minimum power requirements (12.6 volts at 5 milliamperes) are additional features

which help meet the requirements of a high-quality preamplifier.

The circuit described in this article is a single-stage preamplifier that may be used ahead of an existing 2-meter converter or as the input stage of a new solid-state converter. As illustrated in the Figure-2 schematic diagram, the circuit is straightforward and unburdensome, and use of the full-scale template (Figure 3) should expedite its completion in a few hours.

Construction

By following the illustrated layout, builders should be able to avoid any difficulty and at the same time find it relatively simple to align the preamplifier. Use of a copper or brass plate for the chassis will provide a good, solderable RF ground. This brass-plate chassis serves as the cover of a minibox from which a top section has been cut out. If coils are wound as specified and then mounted close to the tuning capacitors, no problem should be encountered in tuning the preamplifier to cover the full 4-

megahertz range of the 2-meter band.

One special precaution must be observed when handling any MOS field-effect transistor; the leads must be shorted together until the device is plugged into its socket or soldered into place. Neglect of this procedure may result in permanent damage to the transistor from electrostatic discharge. After the device is in the socket, the possibility of damage by electrostatic discharge is very remote because of relatively low impedance paths between the transistor elements. MOS-FET's are factory-packaged with thin, bare, protective wiring which shorts the leads. Similar-type wiring should be wrapped around the leads prior to wiring, and should not be removed until soldering is completed. If it becomes necessary to remove a device from a socket, the shorting wire should be replaced prior to removal. No power should be applied to the circuit while the transistor is being inserted into or removed from its socket, and no soldering should be performed at the socket while the device is plugged in.

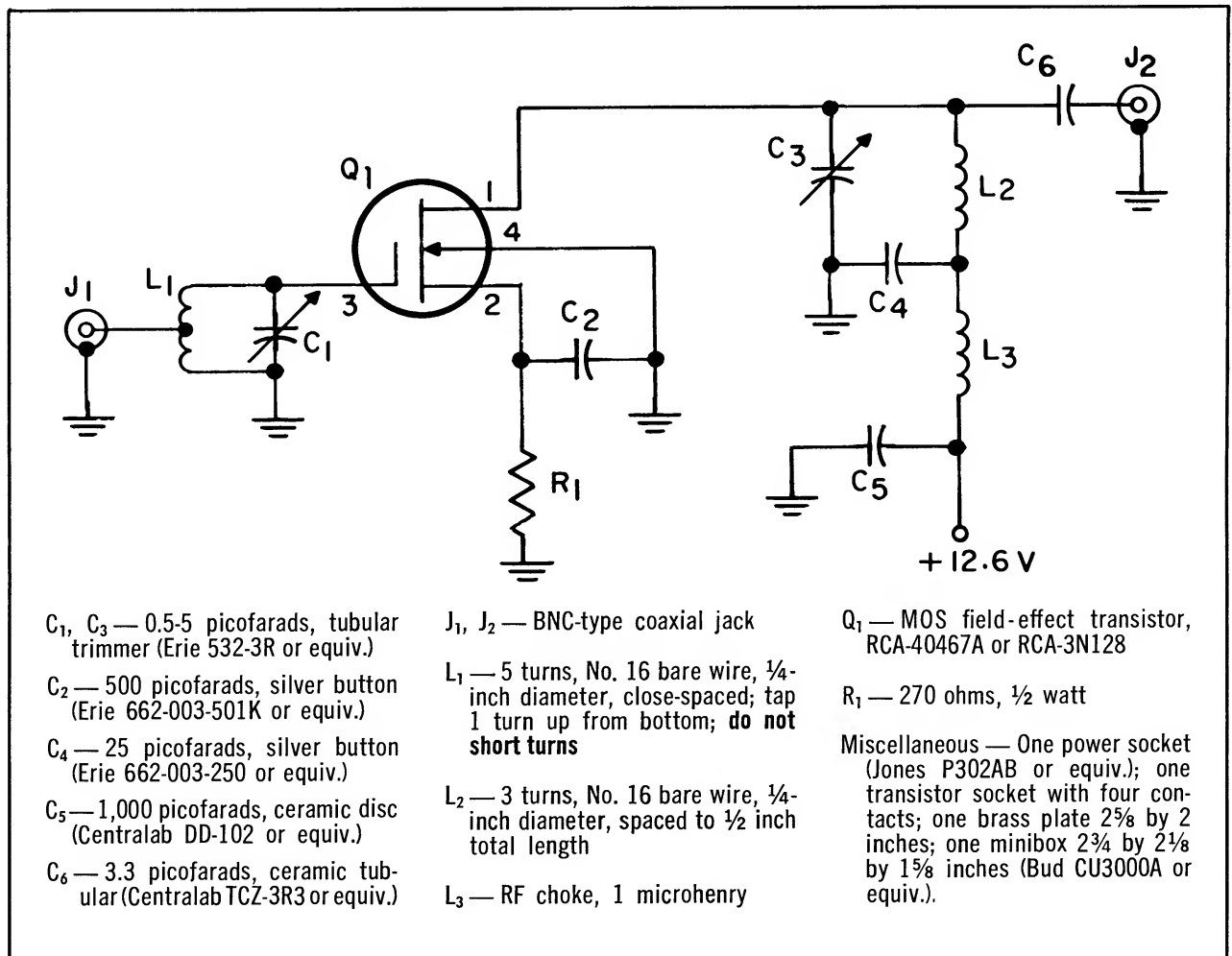

Figure 2: Schematic diagram and parts list for 2-meter preamplifier circuit.

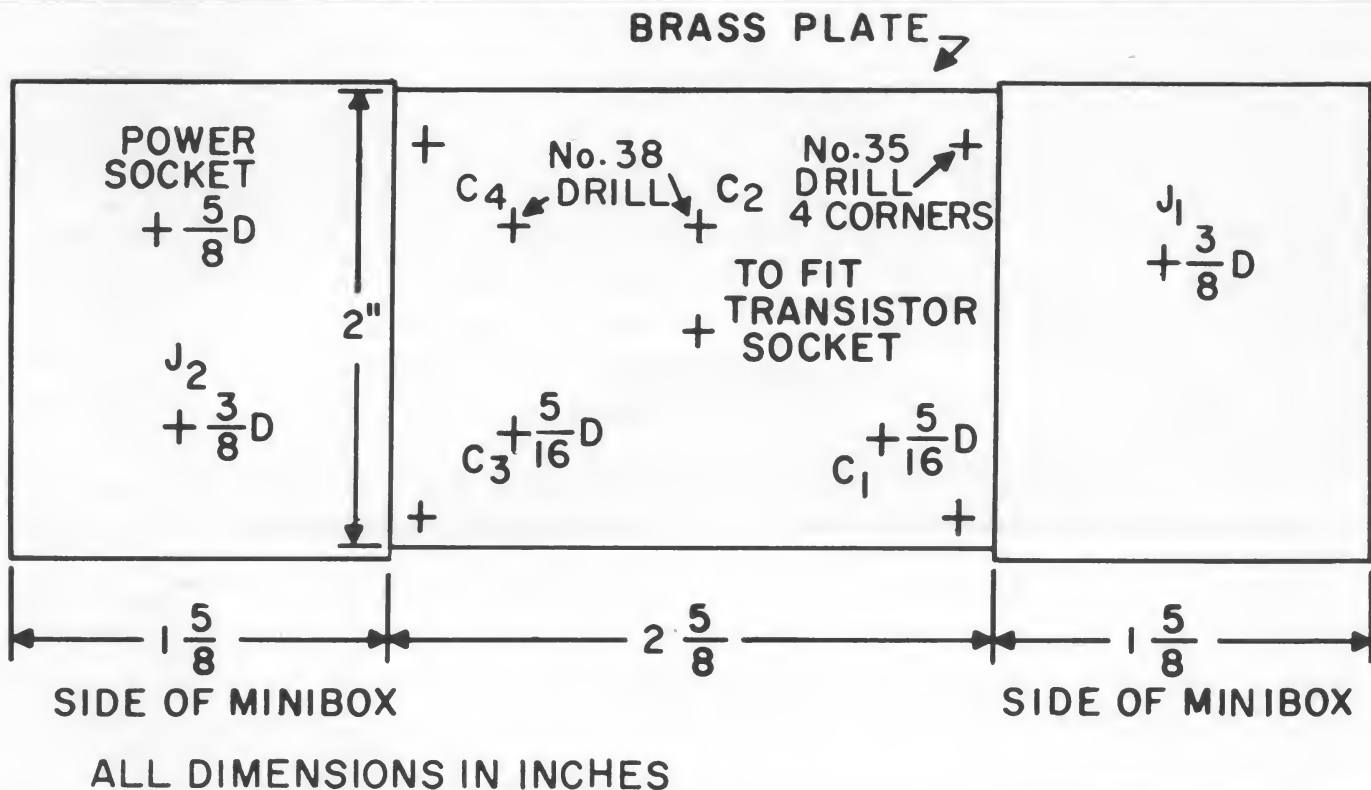

Figure 3: Full-scale drilling template for brass-plate chassis and two sides of minibox.

Preamplifier Alignment

Alignment of the MOS-FET preamplifier can be accomplished without test equipment and consists solely of two screwdriver adjustments. First, the preamplifier is connected to the antenna and 2-meter converter, and power is applied. The 12.6-volt power supply can vary one volt either way without ill effects. This power may be obtained from the same source that feeds the solid-state converter; from the cathode of the audio-output stage of the communications receiver; from a suitable voltage divider to any positive power point in the receiver; or even from a battery. These power sources have been detailed by the author in a previous issue of "Ham Tips" (see footnote reference below).

Next, a signal near 145 MHz is tuned in and the antenna-tuned circuit is peaked for maximum signal. If no maximum can be found, the coil turns should be either squeezed closer or spread slightly apart until peaking occurs. The maximum will not be too sharp since the circuit will pass the full 4-MHz range of the 2-meter band. A

signal near 147 MHz is then tuned in, and the tuning steps repeated at the output circuit. After the preamplifier is checked for even gain across the band, the job is done.

If strong local signals have been blocking your solid-state converter, your troubles are ended. You now have an MOS-FET preamplifier that gives you an improved noise figure, generally better reception, and maintenance-free performance.

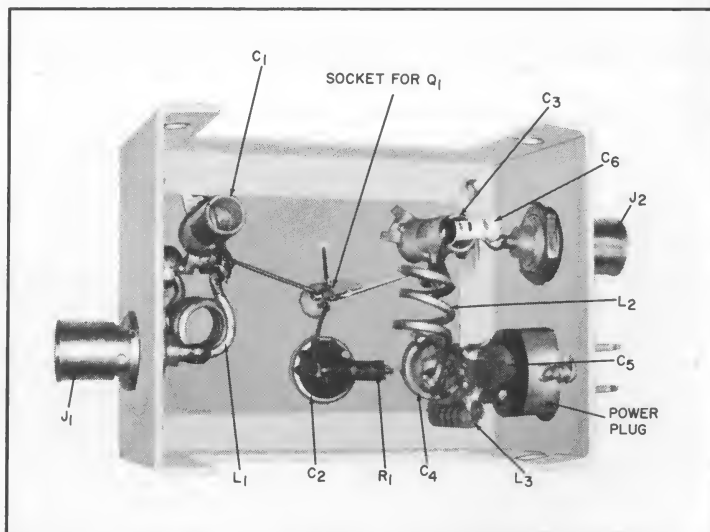

Figure 4: Interior view of assembled preamplifier showing location of all components. Note that short, straight leads are used to obtain good VHF operation.

"All Transistor Two-Meter Converter," Vol. 26, No. 1, Winter, 1965-66.

RCA HAM TIPS is published by the Electronic Components operation of RCA, Harrison, New Jersey. It is available free of charge from participating RCA Industrial Distributors. It is also available on a two-year subscription basis (\$1 for eight issues to cover costs of handling and mailing). Please make check or money order payable to RCA, and remit to "RCA, Section 882, Harrison, N. J. 07029."

GEORGE D. BARBEY CO., INC.
Reading
Lancaster
Pottstown
Lebanon

BLK. RT.
AD'L 0.6¢ PD.



Information furnished by RCA is believed to be accurate and reliable. However, no responsibility is assumed by RCA for its use; nor for any infringements of patents or other rights

of third parties which may result from its use. No license is granted by implication or otherwise under any patent or patent rights of RCA.

Recalled by Popular Demand...

The RCA Amateur Radio Tie Clip!

Handsome than ever, the new, superbly designed RCA Amateur Radio Tie Clip (1G1242) features a miniature code key, reproduced in authentic, three-dimensional detail and finished in 22-karat gold. The miniature code key bears a discrete new RCA monogram, and is mounted on a gleaming, 1½-inch hand-polished bar which offers ample room for the wearer to add his station call letters. Each tie clip comes packaged in a gray felt bag and white jewel box.

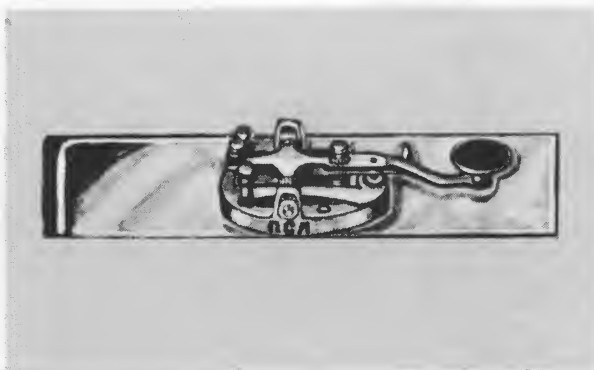

Available in
Mid-January, 1969
From Participating
RCA Distributors