

CCR-81 Computer Cassette Tape Recorder

Catalog Number 26-1208

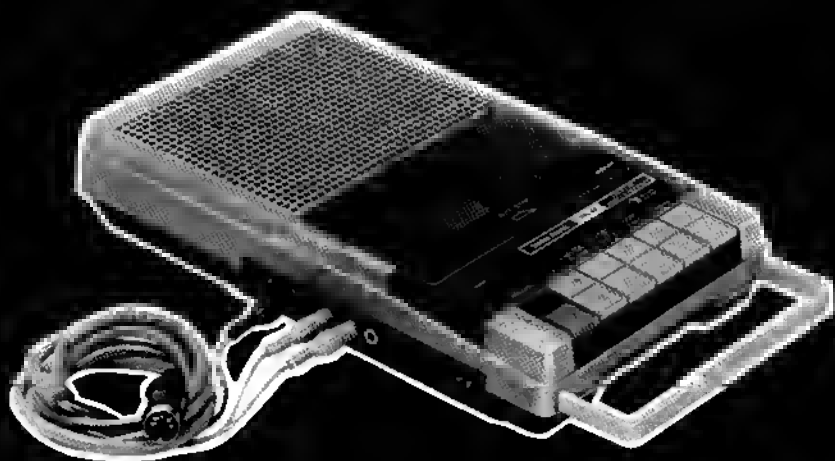

HARDWARE



CUSTOM MANUFACTURED FOR RADIO SHACK, A DIVISION OF TANDY CORPORATION

TERMS AND CONDITIONS OF SALE AND LICENSE OF RADIO SHACK COMPUTER EQUIPMENT AND SOFTWARE
PURCHASED FROM A RADIO SHACK COMPANY-OWNED COMPUTER CENTER, RETAIL STORE OR FROM A
RADIO SHACK FRANCHISEE OR DEALER AT ITS AUTHORIZED LOCATION

LIMITED WARRANTY

I. CUSTOMER OBLIGATIONS

- A CUSTOMER assumes full responsibility that this Radio Shack computer hardware purchased (the "Equipment"), and any copies of Radio Shack software included with the Equipment or licensed separately (the "Software") meets the specifications, capacity, capabilities, versatility, and other requirements of CUSTOMER.
- B CUSTOMER assumes full responsibility for the condition and effectiveness of the operating environment in which the Equipment and Software are to function, and for its installation.

II. RADIO SHACK LIMITED WARRANTIES AND CONDITIONS OF SALE

- A For a period of ninety (90) calendar days from the date of the Radio Shack sales document received upon purchase of the Equipment, RADIO SHACK warrants to the original CUSTOMER that the Equipment and the medium upon which the Software is stored is free from manufacturing defects. THIS WARRANTY IS ONLY APPLICABLE TO PURCHASES OF RADIO SHACK EQUIPMENT BY THE ORIGINAL CUSTOMER FROM RADIO SHACK COMPANY-OWNED COMPUTER CENTERS, RETAIL STORES AND FROM RADIO SHACK FRANCHISEES AND DEALERS AT ITS AUTHORIZED LOCATION. The warranty is void if the Equipment's case or cabinet has been opened, or if the Equipment or Software has been subjected to improper or abnormal use. If a manufacturing defect is discovered during the stated warranty period, the defective Equipment must be returned to a Radio Shack Computer Center, a Radio Shack retail store, participating Radio Shack franchisee or Radio Shack dealer for repair, along with a copy of the sales document or lease agreement. The original CUSTOMER'S sole and exclusive remedy in the event of a defect is limited to the correction of the defect by repair, replacement, or refund of the purchase price, at RADIO SHACK'S election and sole expense. RADIO SHACK has no obligation to replace or repair expendable items.
- B RADIO SHACK makes no warranty as to the design, capability, or suitability for use of the Software, except as provided in this paragraph. Software is licensed on an "AS IS" basis, without warranty. The original CUSTOMER'S exclusive remedy, in the event of a Software manufacturing defect, is its repair or replacement within thirty (30) calendar days of the date of the Radio Shack sales document received upon license of the Software. The defective Software shall be returned to a Radio Shack Computer Center, a Radio Shack retail store, participating Radio Shack franchisee or Radio Shack dealer along with the sales document.
- C Except as provided herein no employee, agent, franchisee, dealer or other person is authorized to give any warranties of any nature on behalf of RADIO SHACK.
- D Except as provided herein, **RADIO SHACK MAKES NO WARRANTIES, INCLUDING WARRANTIES OF MERCHANTABILITY OR FITNESS FOR A PARTICULAR PURPOSE.**
- E Some states do not allow limitations on how long an implied warranty lasts, so the above limitation(s) may not apply to CUSTOMER.

III. LIMITATION OF LIABILITY

- A EXCEPT AS PROVIDED HEREIN, RADIO SHACK SHALL HAVE NO LIABILITY OR RESPONSIBILITY TO CUSTOMER OR ANY OTHER PERSON OR ENTITY WITH RESPECT TO ANY LIABILITY, LOSS OR DAMAGE CAUSED OR ALLEGED TO BE CAUSED DIRECTLY OR INDIRECTLY BY "EQUIPMENT" OR "SOFTWARE" SOLD, LEASED, LICENSED OR FURNISHED BY RADIO SHACK, INCLUDING, BUT NOT LIMITED TO, ANY INTERRUPTION OF SERVICE, LOSS OF BUSINESS, OR ANTICIPATORY PROFITS OR CONSEQUENTIAL DAMAGES, RESULTING FROM THE USE OR OPERATION OF THE "EQUIPMENT" OR "SOFTWARE" IN NO EVENT SHALL RADIO SHACK BE LIABLE FOR LOSS OF PROFITS, OR ANY INDIRECT, SPECIAL, OR CONSEQUENTIAL DAMAGES ARISING OUT OF ANY BREACH OF THIS WARRANTY OR IN ANY MANNER ARISING OUT OF OR CONNECTED WITH THE SALE, LEASE, LICENSE, USE OR ANTICIPATED USE OF THE "EQUIPMENT" OR "SOFTWARE".

NOTWITHSTANDING THE ABOVE LIMITATIONS AND WARRANTIES, RADIO SHACK'S LIABILITY HEREUNDER FOR DAMAGES INCURRED BY CUSTOMER OR OTHERS SHALL NOT EXCEED THE AMOUNT PAID BY CUSTOMER FOR THE PARTICULAR EQUIPMENT OR SOFTWARE INVOLVED.

- B RADIO SHACK shall not be liable for any damages caused by delay in delivering or furnishing Equipment and/or Software.
- C. No action arising out of any claimed breach of this Warranty or transactions under this Warranty may be brought more than two (2) years after the cause of action has accrued or more than four (4) years after the date of the Radio Shack sales document for the Equipment or Software, whichever first occurs.
- D Some states do not allow the limitation or exclusion of incidental or consequential damages, so the above limitation(s) or exclusion(s) may not apply to CUSTOMER.

IV. RADIO SHACK SOFTWARE LICENSE

RADIO SHACK grants to CUSTOMER a non-exclusive, paid-up license to use the RADIO SHACK Software on one computer, subject to the following provisions:

- A Except as otherwise provided in this Software License, applicable copyright laws shall apply to the Software.
- B Title to the medium on which the Software is recorded (cassette and/or diskette) or stored (ROM) is transferred to CUSTOMER, but not title to the Software.
- C CUSTOMER may use Software on one host computer and access that Software through one or more terminals if the Software permits this function.
- D CUSTOMER shall not use, make, manufacture, or reproduce copies of Software except for use on one computer and as is specifically provided in this Software License. Customer is expressly prohibited from disassembling the Software.
- E. CUSTOMER is permitted to make additional copies of the Software only for backup or archival purposes or if additional copies are required in the operation of one computer with the Software, but only to the extent the Software allows a backup copy to be made. However, for TRS80's Software, CUSTOMER is permitted to make a limited number of additional copies for CUSTOMER'S own use.
- F. CUSTOMER may resell or distribute unmodified copies of the Software provided CUSTOMER has purchased one copy of the Software for each one sold or distributed. The provisions of this Software License shall also be applicable to third parties receiving copies of the Software from CUSTOMER.
- G All copyright notices shall be retained on all copies of the Software.

V. APPLICABILITY OF WARRANTY

- A. The terms and conditions of this Warranty are applicable as between RADIO SHACK and CUSTOMER to either a sale of the Equipment and/or Software License to CUSTOMER or to a transaction whereby RADIO SHACK sells or conveys such Equipment to a third party for lease to CUSTOMER.
- B The limitations of liability and Warranty provisions herein shall inure to the benefit of RADIO SHACK, the author, owner and/or licensor of the Software and any manufacturer of the Equipment sold by RADIO SHACK.

VI. STATE LAW RIGHTS

The warranties granted herein give the original CUSTOMER specific legal rights, and the original CUSTOMER may have other rights which vary from state to state.

CONTROLS AND CONNECTIONS

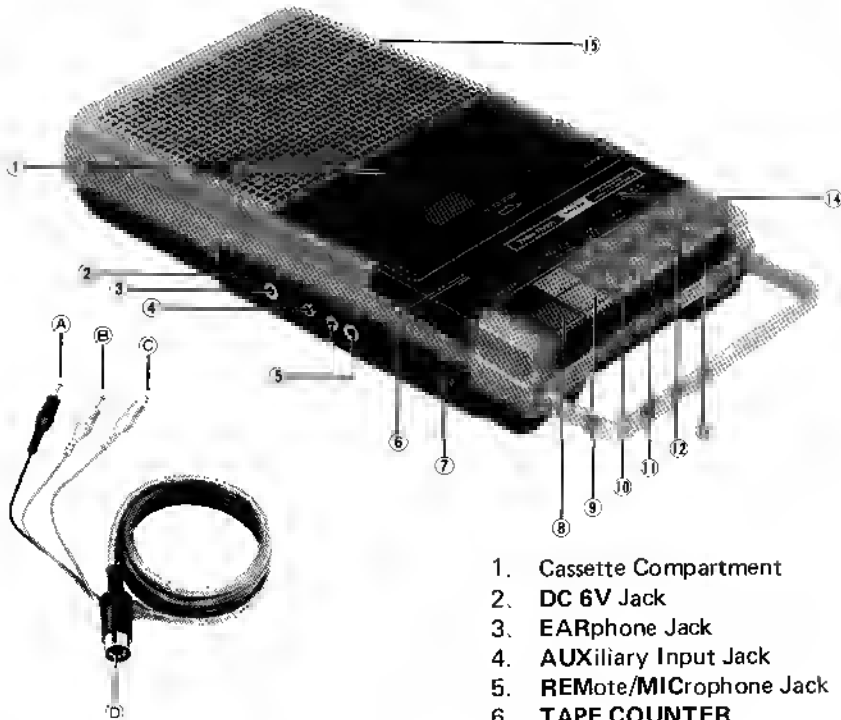

1. Cassette Compartment
2. DC 6V Jack
3. EARphone Jack
4. AUXiliary Input Jack
5. REMote/MICrophone Jack
6. TAPE COUNTER
7. VOLUME Control
8. RECDRO Key
9. PLAY Key
10. REWINO/REVIEW Key
11. FAST-Forward/CUE Key
12. STOP/EJECT Key
13. PAUSE Key
14. BATTERY/RECORD LED Indicator
15. AC Line Cord Receptacle

- A. Tape output plug (to EARphone Jack)
B. Tape input plug (to AUXiliary Input Jack)
C. Tape control plug (to REMote Jack)
D. Computer cassette plug
(to TAPE output on computer)

FEATURES

CONNECTION CABLE: Simple connection to TRS-80 cassette jack with supplied cable.

TRS-80 CONTROLS THE CCR-81: Allows the TRS-80 to start or stop the tape while loading or saving programs and data.

CUE/REVIEW FUNCTION: Enables instant Fast Forward or Rewind while in either Record or Play mode independent of the TRS-80. Lets you quickly locate any desired portion of the tape.

AUTOMATIC SHUT-OFF MECHANISM: Automatically shuts off the recorder when the end of the tape is reached while in the Play or Record mode and/or loading or saving programs and data files. This saves wear and strain on the unit, the tape and the batteries.

BUILT-IN A.L.C. CIRCUIT: Enables you to automatically obtain perfect recording level for both voice and music recording — no need to adjust Volume while recording.

TAPE COUNTER: Helps you to quickly find a specific section of the tape.

MECHANICAL PAUSE: Permits you to stop the tape instantaneously either in Record or Play mode.

ULTRA-CONVENIENT 3-WAY POWER: Use with AC, built-in batteries or with an external source of 6 volts DC (for example, with our optional Car Adapter and use in your vehicle). (DC 6V jack not available on UK models.)

BATTERY/RECORD LED INDICATOR: Serves two functions. During Recording, the LED will flicker on peaks of recording signal. In any other function, it will give you an indication of the battery condition — the LED lights up when the batteries need to be replaced.

You may note that **BATTERY** Indicator flashes briefly as you switch function keys. This is normal and does not mean the batteries are weak (if the LED stays on, the batteries do need to be replaced).

The **BATTERY** Indicator is designed so that the LED lights up any time the voltage drops below the required level.

PREPARATION FOR USE

OPERATING ON AC POWER: Connect one end of the AC power cord to the AC IN of the recorder, plug the other end into a convenient 120V outlet. (220/240V AC 50 Hz outlet where the sets are marked on the bottom for European and Australian models.) Connecting the cord to the set automatically disconnects the internal battery circuit. **Never leave the cord plugged into an AC outlet when it is not connected to the recorder.**

Note: We recommend that you always use AC power when using the CCR-81 with a TRS-80 computer.

USE WITH BATTERIES

INSTALLING BATTERIES: Your recorder requires four (4) "C" size 1-1/2 volt batteries. We recommend Radio Shack Catalog Number 23-581 or 23-551. To load batteries, turn the recorder over and open the battery compartment cover. Insert batteries as indicated within compartment, then close the cover.



WARNING: Weak batteries, even "leak-proof" types, may swell and leak. To avoid damage to the recorder, remove batteries when weak or if you are going to store the recorder for a period of time.

DC 6V Jack: When using the unit in your vehicle, you can conserve battery power by using a power adapter (such as Radio Shack Catalog Number 14-844C) connected via a cigarette lighter socket. Use the DC 6V jack on the side to connect the adapter plug. **Set the switch on 14-844C to the 6 volt position.**

INSERTING CASSETTE: Before inserting or removing cassette, be sure to press the **STOP/EJECT** Key. Open the cassette lid by pressing the **STOP/EJECT** Key. Hold the cassette with the open tape side toward you and insert it into the opening so that the full reel is on your left and then close the lid.

After you've completed recording or playing on one side of the cassette, open the lid, turn the cassette over and re-insert. You are ready to record or play the second track.

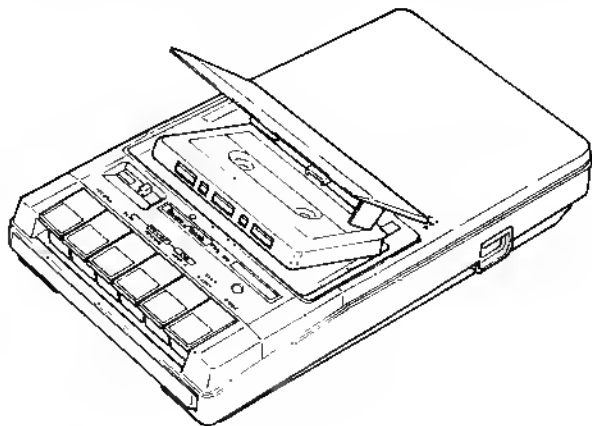

OPERATION WITH THE TRS-80

You can use the supplied cable to connect to the computer, TRS-80.

1. Connect to **EAR**phone Jack on cassette unit via the red tape output plug.
2. Connect to **AUX**iliary Input Jack on cassette unit via the gray tape input plug.
3. Connect to **REM**ote Jack on cassette unit via the gray tape control plug.
4. Connect to **TAPE** output on computer via computer cassette plug.

LOADING A PROGRAM OR DATA FILE FROM TAPE

1. Set the volume to the correct level for your computer (see the computer owner's manual for details). If you have trouble loading programs or inputting data, try adjusting the volume.
2. Be sure the tape is positioned to just before the start of the recorded program or data. Usually, this means the tape should be rewound all the way (or positioned using the counter, as explained in the Note later on).
3. Before the computer is ready to load the program or input the data, press **PLAY** on the recorder. The computer will control the tape motion. While the computer is actually receiving data from the recorder, the LED will not be on.
4. When the computer has completed the tape operation, press **STOP**.

SAVING A PROGRAM OR DATA FILE ON TAPE

1. Insert a blank (new or bulk-erased)tape, and rewind it to the beginning of the tape (if using tape with a leader, be sure to advance it past the leader to the beginning of the recording tape).
2. Before the computer is ready to save the program or data, press **RECORD** and **PLAY** together. Both keys should remain "down". You do not need to adjust the volume setting; the cassette unit does that automatically during record operations.
3. You can now save the program or data in tape. While data is being saved, the LED will illuminate. The computer will turn the tape on and off as necessary to complete the operation.
4. When the operation is complete, press **STOP** on the recorder.

Note: It is possible to record two or more programs or data files on one side of a tape. However, this takes a little extra care and attention on your part. First rewind the tape and reset the tape counter. Then keep a written account of the counter reading where each program or data file starts.

When you are ready to load in a particular program or data file, rewind the tape, reset the counter, then use fast-forward or rewind to position the tape just ahead (one digit) of the desired tape section.

OTHER USES FOR THE RECORDER TO PLAYBACK

1. Rewind the tape by pressing the **REWIND/REVIEW** Key.
2. Press the **STDP/EJECT** Key when you reach that section of the tape you wish to play.
3. Press the **PLAY** Key and adjust the **VOLUME** Control for the desired sound level from the speaker.
4. To stop playback, press the **STDP/EJECT** Key. If you want, let the tape play to the end and the unit will automatically shut off the power.
5. When playing back a recorded tape, make sure the **RECORD** Key is not pressed down (otherwise the recorded tape will be erased).
6. For greater fidelity, you can play back the sound through an external speaker which has an impedance of 8 ohms. Connect via a patch cord into the **EARPHONE** Jack on the side of the recorder (check your Radio Shack store for all such accessories).

CAUTION: If you use adapters other than Radio Shack's recommended type, you must be sure the voltage is correct (6 volts DC only) and that the center terminal of the connector is negative. Failure to observe these two vital points may result in damage to your recorder and/or adapter.

To advance tape rapidly, press **FAST-Forward/CUE**. When you reach the approximate position you want (as noted by the **TAPE COUNTER**), press **STOP/EJECT** and then press **PLAY**.

To rewind tape rapidly, press **REWIND/REVIEW**. When you reach the desired position on the tape (follow the **TAPE COUNTER**), press **STOP/EJECT** and then **PLAY**.

REWIND/REVIEW

The **REWIND/REVIEW** Key has a dual function. To repeat something that has just been played or to review something that has just been recorded, press the **REWIND/REVIEW** Key.

If in the record mode, the **RECORD** Key will be released and the tape will be rewound at high speed; the recorded sound will be heard as an aid to locating any desired portion of the tape. Release the key and the unit will return to the normal play mode.

If you press **REWIND/REVIEW** while the tape is stopped, the key will lock down and the tape will rewind at high speed. The sound is automatically muted during rewind (Review functions only when in Record or Play).

FAST-Forward/CUE

The **FAST-F** Key also has a dual function. If you press it, while in the Play mode, the tape will be advanced rapidly — at the same time, you'll be able to hear any signal on the tape (makes it easy to locate the end of a passage). When you release **FAST-F**, the CCR-81 will return to normal Play speed.

If you press **FAST-F** during Record mode, the **RECORD** Key will pop up and the tape will be advanced rapidly. Releasing the key will return you to normal Play.

If not in either Play or Record, the **FAST-F** Key will lock down, but you will not be able to hear tape sounds. (Cue functions only when in Record or Play.)

PAUSE

PAUSE provides a convenient method of starting and stopping the recorder whenever it is playing or recording. However, if you are rewinding a cassette or have pressed **FAST-Forward**, pause will not "pause" operation.

To temporarily stop tape movement press **PAUSE**; press **PAUSE** once more to restart tape motion.

TO RECORD

RECORDING WITH EXTERNAL MICROPHONE

Connect an optional microphone to the **REMOte/MICROphone** Jacks. Use the remote switch on the microphone to temporarily stop recording.

RECORDING FROM RADIO OR PHONOGRAPH

1. Connect signal from the external source into the **AUX** Jack (use a suitable patch cord with proper plug).
2. Set the Volume control of the external sound source to a normal listening level.
3. Follow the instructions noted previously.

Once you've decided on the source, the recorder sets its recording level automatically. The **VOLUME** Control will have no effect on the sound.

When both MIC and AUX jacks are connected, only MIC is functional.

TO ERASE TAPE

Each time you make a recording, any previous recording on the tape is automatically erased; thus, the tape may be used for new recording as many times as you wish. If you do want to erase a cassette, use our Bulk Tape Eraser.

ACCIDENTAL ERASURE PREVENTION

Cassettes have a built-in device to automatically prevent erasure of a previous recording. It is a small plastic tab at the back of the cassette. To activate the erase-protect feature, break off the plastic tab with a screwdriver.

There is a tab for each side; be sure you break off the correct tab. (See illustration below.) If you do want to record again on that cassette, put a piece of tape over the hole where you broke off the tab.

CAUTION: If you have a cassette with the tabs broken off, don't try to force the **RECORD** Key down. You can damage a part of the mechanism.

ERASE PREVENTION TABS

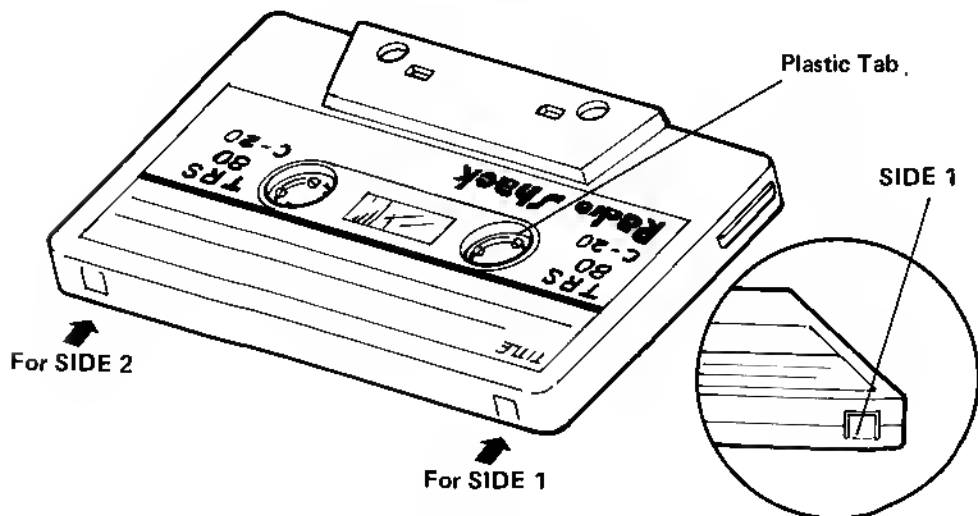

MAINTENANCE

With batteries and cassette removed, and with cassette lid up, press down the **PLAY** Key, exposing the erase and record heads and the rubber drive wheel. Clean these points, using a cotton swab moistened with denatured alcohol (not rubbing alcohol) or with a special head cleaning fluid. Your Radio Shack store has these items. To insure good recording and playback results, clean after the first 6 hours of operation (and every 6-8 hours of operation after that). After cleaning, be sure to press the **STOP/EJECT** Key, so that these parts may return to their normal operating position for cassette holding. For easy cleaning, we recommend our Cassette Head Cleaner Tape, Catalog Number 44-1160.

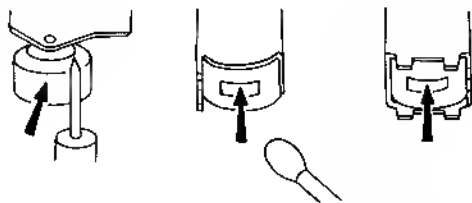

It is a good idea to periodically demagnetize the tape heads too. Use one of our **Tape Head Demagnetizers**.

You can clean and demagnetize in one simple operation just by playing our **Cassette Demagnetizer Tape, 44-631**.

If you use the longer, thinner tapes (C-90, C-120, etc.), it is absolutely vital that you keep your recorder clean. Failure to do so will result in poor tape handling, improper auto-stop function and serious tape wrap ups. Clean the tape handling parts well and often.

CAUTION:

Do not expose the tape recorder or a cassette to high temperature or high humidity. Do not touch the tape heads with screwdrivers or other metal objects or any magnetic object.

Remove batteries when recorder is not in use for more than a month, because battery leakage may damage the unit. **Don't leave weak or dead batteries in the recorder.**

WARNING: TO PREVENT FIRE OR SHOCK HAZARD, DO NOT EXPOSE THIS APPLIANCE TO RAIN OR MOISTURE.

SPECIFICATIONS

Tape System	: 2-track monaural
Tape Speed	: 4.75 cm/sec.
Wow and Flutter (WRMS)	: 0.15%
Signal-to-Noise Ratio (DC/AC)	: 49/40 dB
Semiconductors	: 1 IC 5 transistors 7 diodes
Erase System	: DC Erasing
AGC delaytime at Recording	: 0.4 sec.
Turn on time at Record	: 0.4 sec.
Record System	: AC Bias
Power Requirement	: DC 4 "C" cells AC 120V 60 Hz 230V 50 Hz 240V 50 Hz
Dimensions	: (H)10-15/32" x (W)5-3/4" x (D)1-53/64" (266 mm x 146 mm x 46.5 mm)
Weight	: 2.2 lb (1 kg)

SCHEMATIC DIAGRAM

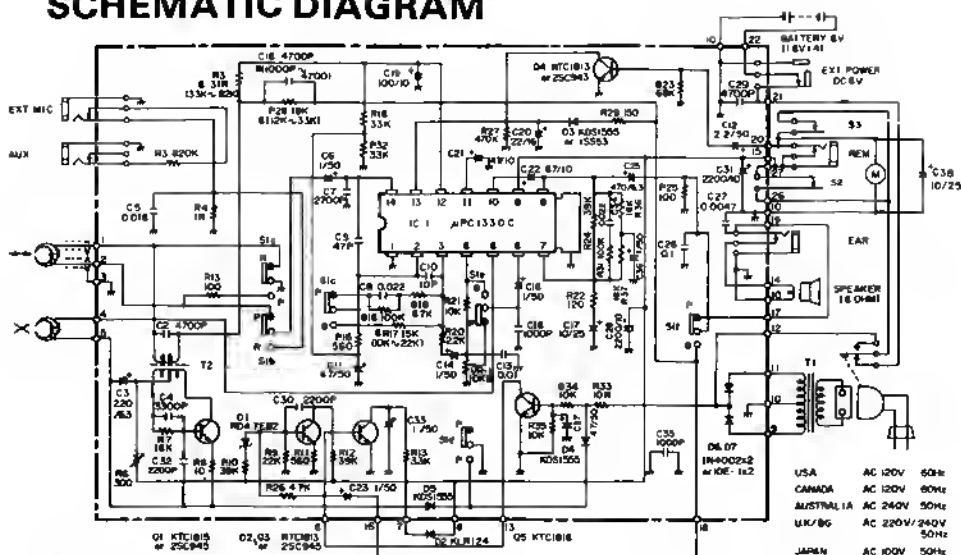

NOTES

- 11) SWITCH S14 & S11 SHOWS IN PI PLAY POSITION
- 12) ALL RESISTANCE VALUES ARE INDICATED IN "OHM" OR "KOHM"
- 13) ALL CAPACITANCE VALUES ARE INDICATED IN "μF" OR "nF"
- 14) SWITCH S2 IS TURN ON AT PLAY AND RECORD POSITION
- 15) SWITCH S3 IS TURN ON AT FF AND RW POSITION

Schematic subject to change without notice. For most accurate Schematic (and parts) contact Radio Shack, National Parts Dept., Fort Worth, TX 76101

In UK, contact Tandy Electronics, National Parts Dept., Bilston Road, Wednesbury West Midlands WS10 7JN.

In Australia, contact Tandy Corporation (Australian Branch) National Parts Dept., 280-316 Victoria Road, Rydalmere NSW 2116

RADIO SHACK, A DIVISION OF TANDY CORPORATION

**U.S.A.: FORT WORTH, TEXAS 76102
CANADA: BARRIE, ONTARIO L4M 4W5**

TANDY CORPORATION

AUSTRALIA	BELGIUM	U K
280-316 VICTORIA ROAD RYDALMERE, N S W 2116	PARC INDUSTRIEL DE NANINNE 5140 NANINNE	BILSTON ROAD, WEDNESBURY WEST MIDLANDS WS10 7JN