

TRS-80 CCR-82 Computer Cassette Recorder

Operation Manual
Catalog Number 26-1209

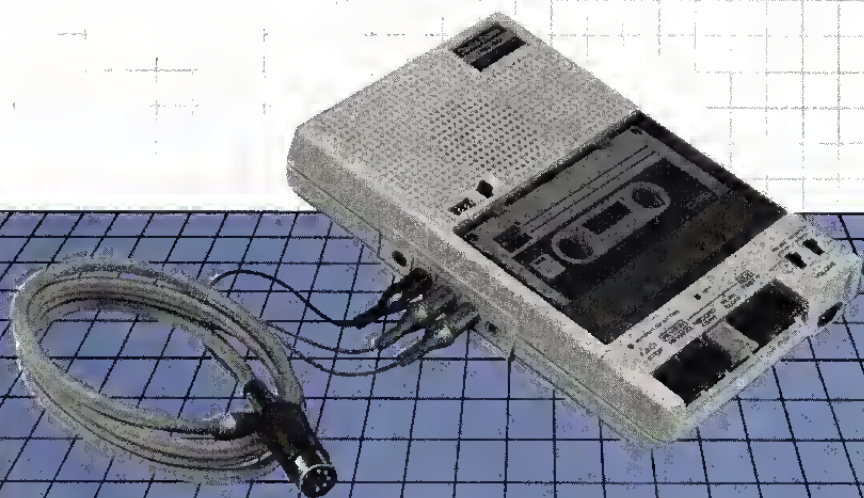

CUSTOM MANUFACTURED FOR RADIO SHACK, A DIVISION OF TATCOY CORPORATION

Contents

Controls and Connections	1
Features	2
Preparation for Use	3
Power Source	3
Inserting the Cassette	4
Connecting to the Computer	4
Operation with the Computer	5
Loading a Program or Data File from Tape	5
Locating a Program or Data on the Tape	5
Saving a Program or Data File on the Tape	6
Other Uses for the Recorder	8
To Play Back	8
To Record	9
To Erase Tape	9
Accidental Erasure Prevention	10
Maintenance	11
Specifications	12
Schematic Diagram	13

Controls and Connections



- (A) Tape output plug (to EARPHONE Jack)
- (B) Tape input plug (to AUXILIARY Input Jack)
- (C) Tape control plug (to REMOTE Jack)
- (D) Computer cassette plug
(to TAPE, CASS, or CASSETTE BIN plug)

- ① Tape Counter
- ② Cassette Compartment
- ③ DC 6V Jack
- ④ EARPHONE Jack
- ⑤ AUXILIARY Jack
- ⑥ REMOTE/MICROPHONE Jacks
- ⑦ RECORD/LOW BATTERY Indicator
- ⑧ STOP/EJECT Key
- ⑨ REWIND/REVIEW Key
- ⑩ RECORD/SAVE Key
- ⑪ PLAY/LOAD Key
- ⑫ FAST-FORWARD/CUE Key
- ⑬ VOLUME Control
- ⑭ MONITOR Switch
- ⑮ PAUSE Switch
- ⑯ DATA Indicator

Features

- **Computer Controlled:** Allows the Computer to start or stop the tape to load or save programs and data.
- **CUE/REVIEW Functions:** Enable instant fast-forward or rewind while in either save/record or load/play mode, independent of the Computer. These functions allow you to quickly locate any desired portion of the tape.
- **MONITOR Switch:** Enables monitoring of the sound while saving programs and data.
- **DATA Indicator:** Illuminates to show that programs and data are being loaded to the Computer. Also used with CUE/REVIEW to locate data and/or programs on the tape.
- **VOLUME Control with Preset Marker:** Set to the marker position for program and data loading.
- **Automatic Shut-Off Mechanism:** Automatically shuts off the recorder when the end of the tape is reached while in the play/load or record/save mode. This saves wear and strain on the unit, the tape, and the batteries.
- **Built-In A.L.C. (Automatic Level Control) Circuit:** Enables you to automatically obtain perfect recording levels for both recording music and saving programs/data -- no need to adjust the volume.
- **Tape Counter:** Helps you to quickly find a specific section of the tape.
- **Switchable PAUSE:** Permits you to stop the tape instantaneously, either in record/save or play/load mode -- or you can switch off the remote function of the computer to allow for manual control of the tape movement.
- **Convenient 3-Way Power:** Can be powered by the internal batteries, by an AC power source via AC adapter, or by a car battery via DC car adapter.
- **RECORD/LOW BATTERY Indicator:** Serves two functions. During recording/saving, the LED will light to show the presence of a recording signal. In any other function, it will give you an indication of the battery condition -- the LED lights up when the batteries need to be replaced. You may note that the **LOW BATTERY** Indicator flashes briefly as you switch function keys. This is normal and does not mean the batteries are weak. If the LED stays on, the batteries need to be replaced. The **LOW BATTERY** Indicator is designed so that the LED lights up any time the voltage drops below the required level. Don't let the batteries get so weak that they cannot light the LED.

Preparation for Use

Power Source

- **Installing Batteries:** Your recorder requires four (4) AA size 1-1/2 volt batteries. (We recommend Radio Shack Energcell batteries, catalog number 23-582 or 23-552). To load batteries, turn the recorder over and open the battery compartment cover. Insert batteries as indicated within the compartment; then close the cover.

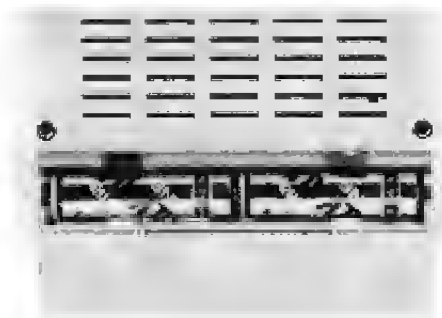

WARNING: Weak batteries, even “leak-proof” types, may swell and leak. To avoid damage to the recorder, remove batteries when they are weak or if you are going to store the recorder for an extended period of time.

- **DC 6V Jack:** When you want to use the unit with standard AC power (and save the battery power), use the AC adapter (Radio Shack Catalog Number 273-1454) [for 240V AC, use 14-9854 (UK) or 14-9521 (Australia)]. Connect it to the DC 6V jack on the unit and plug the adapter into an AC outlet.
- **Car Battery:** If your vehicle has a 12-volt, negative ground electrical system, you can provide power to your recorder from your car battery. Use our DC auto adapter (14-844D). Set the switch on the adapter to the 6V position and connect it to the DC 6V jack. When the adapter is connected, the internal batteries are automatically disconnected.

CAUTION: If you use an adapter other than Radio Shack’s recommended type, you must be sure that the voltage is correct (6V DC only) and that the center terminal of the connector is negative. Failure to observe these two vital points may result in damage to your recorder and/or adapter.

Inserting the Cassette

Before inserting or removing the cassette, be sure to press the **STOP/EJECT** key to cancel any functions that may have been previously selected. Open the cassette lid by pressing the **STOP/EJECT** key again. Hold the cassette with the open side toward you and insert it into the opening so that the full reel is on your left; then close the lid.

After you've completed recording or playing on one side of the cassette, open the lid, turn the cassette over and re-insert it. You are now ready to record or play the second side.

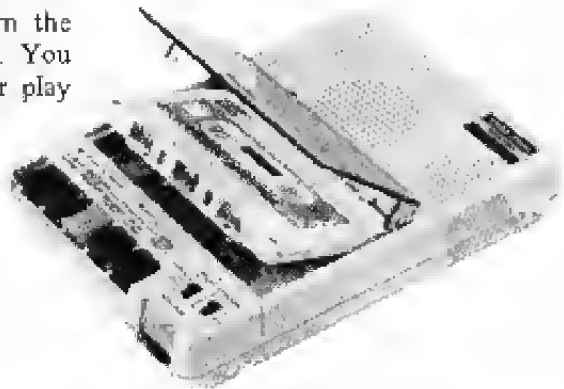

Connecting to the Computer

CAUTION: Some Computers require their own connection cables. Refer to your Computer and/or cassette interface owner's manual.

Use the cable to connect to the Computer.

1. Connect to the **EAR**phone jack on the cassette unit via the black tape output plug.
2. Connect to the **AUX**iliary* jack on the cassette unit via the gray tape input plug.
3. Connect to the **RE**Mote jack on the cassette unit via the gray tape control plug.
4. Connect to the Cassette Tape output on the Computer via the Computer cassette plug.

* Some of the Computers, especially the Pocket Computers, need to be connected to the **MIC** jack, not the **AUX** jack. (Refer to your Computer and/or cassette interface owner's manual.)

Note: Some connecting cables have plugs that are too long to fit into the jacks on the CCR-82. When using a connection cable other than the one supplied with your CCR-82, insert the plug until you feel a slight "catch". Do not force the plug all the way in.

Operation with the Computer

Loading a Program or Data File from Tape

1. Set the **VOLUME** control to the **P** marker. If you have trouble in loading, adjust the **VOLUME** setting. When you have found the **VOLUME** setting that works best with your Computer, you may want to mark that position as your preset marker on the **VOLUME** knob.
2. Be sure the tape is positioned to the point just before the beginning of recorded programs or data. Usually this means the tape should be rewound all the way (or positioned using the tape counter). The **CUE/REVIEW** functions are quite handy for this purpose.
3. If your Computer has a remote control function, set the **PAUSE** switch on the CCR-82 to the **OUT** position. If it does not have a remote control function, set the **PAUSE** switch to **IN** before the Computer is ready to load the program or input the data.
4. Press **PLAY** on the cassette unit. Then type **CLOAD** and press **ENTER** (or the equivalent command on your Computer). If you set the **PAUSE** switch to **IN** in the preceding step, now set it to **OUT** before pressing **ENTER**. The tape will begin moving and programs or data will be transferred to the Computer. While the CCR-82 is sending data to the Computer, the **DATA LED** will blink.
5. When a Computer remote control function has completed the tape operation, it will stop automatically. For a Computer without a remote control function, watch the **DATA LED**; when the LED goes off, it means the end of the program/data has been reached. Press **STOP**.

CAUTION: Be careful not to leave the **RECORD** and/or **PLAY** buttons engaged for long periods of time. Failure to observe this warning could cause a flut spot on the drive wheel, resulting in sound distortion.

Locating a Program or Data on the Tape

The CCR-82 allows fast-forward/rewind functions, which can operate apart from the remote control of the Computer. That is, you can do fast-forward or rewind, even with the Computer connected to the **REMOte** jack. With the **PLAY** key pressed down, press and hold **FAST-F/CUE** or **REWIND/REVIEW**. Watch the **DATA LED** or listen to the recorded sound to help you locate the beginning or end of the program or data on the tape. Release the key, and the CCR-82 is again under the control of the Computer. If you do not press the **PLAY** key, the **FAST-F/CUE** or **REWIND/REVIEW** key will lock down and the sound is automatically muted.

Saving a Program or Data File on the Tape

1. Insert a blank (new or bulk-erased) tape, and rewind it to the beginning of the tape. If you use a tape with a leader, be sure to advance it past the leader to the beginning of the recording tape.
2. If your Computer has a remote control function, set the **PAUSE** switch on the CCR-82 to the **OUT** position. (If it does not have a remote control function, set the **PAUSE** switch to **IN** before the Computer is ready to save the program or the data.)
3. Press **RECORD** on the cassette unit. (When **RECORD** is pressed, the **PLAY** button automatically goes down.) Then type **CSAVE** and press **ENTER** (or the equivalent command on your Computer). If you set the **PAUSE** switch to **IN** in the preceding step, now set it to **OUT** before pressing **ENTER**. The tape will begin moving and programs or data will be saved onto the CCR-82. While the CCR-82 is receiving data, the **RECORD** LED will blink. There is no need to adjust the **VOLUME** setting; the CCR-82 does that automatically during the save operation.
4. When the save operation is complete, a Computer with the remote control function will stop the tape automatically. If your Computer does not have the remote control function, press **STOP** at the end of the save operation.

Notes:

1. When you are saving data on a cassette tape with a Computer that does not have a remote control function, we recommend that you write a program such that the end of data transfer is shown on the display. Then you can manually stop the CCR-82 without much loss of the tape.
2. It is possible to record two or more programs or data files on one side of a tape. However, this takes a little extra care and attention on your part. First, rewind the tape and reset the tape counter. Then keep a written record of the counter reading where each program or data file starts.

When you are ready to load in a particular program or data file, rewind the tape, reset the counter, and then use **FAST-FORWARD/REWIND** to position the tape just ahead of the desired tape section. Remember, fast-forward/rewind can be done manually without disconnecting the **REMOte** jack.

We've already noted the special features of your CCR-82; here are some suggestions to get most from your unit.

- On ordinary cassette recorders, you would have to disconnect the plug from the earphone jack to monitor the sound from the speaker. On the CCR-82, the **MONITOR** switch allows you to listen to the sound without disconnecting the **EAR**phone jack. Set the **MONITOR** switch to **IN** for listening, to **OUT** if you do not need monitoring.
- The remote control jack on normal cassette units turns the unit on/off remotely; you must turn the unit on first before using fast-forward/cue or rewind/review. We have built in another leaf switch so you can fast-forward/rewind without disconnecting the **REM**ote jack.
- Another convenience is the **PAUSE** switch. Many computers have the remote control function. Set the switch to **OUT** for such a Computer. If your Computer does not have the remote control function, use the **IN** and **OUT** positions to stop/start tape movement; these positions function the same as the pause switch on ordinary tape recorders.

To avoid remote control by your Computer, set the **PAUSE** switch to **REM OFF**; then you can manually play (or record) tape without disconnecting the remote plug.

Other Uses for the Recorder

To Play Back

1. Insert the pre-recorded cassette tape.
2. Rewind the tape by pressing the **REWIND/REVIEW** key.
3. Press the **STOP/EJECT** key when you reach the section of the tape you wish to play.
4. Press **PLAY**. Adjust the **VOLUME** control to a comfortable setting.
5. To stop playback, press **STOP/EJECT**. When the tape reaches the end, the unit will automatically shut off the power.
6. When you want to listen privately, plug an earphone into the **EAR**phone jack. Or, for greater fidelity, you can play back the sound through an external speaker which has an impedance of 8 ohms. Connect the speaker via a patch cord plugged into the **EAR**phone jack. (Visit your local Radio Shack store for all accessories.)

To advance the tape rapidly, press **FAST-F/CUE**. When you reach the approximate point you want, press **STOP/EJECT** and then press **PLAY**.

To rewind the tape rapidly, press **REWIND/REVIEW**. When you reach the approximate point you want, press **STOP/EJECT** and then press **PLAY**.

In each case, always press **STOP/EJECT** before pressing **PLAY**. Abrupt change in tape speed/direction can damage the tape.

When you press and hold **FAST-F/CUE** or **REWIND/REVIEW** while the **PLAY** key is engaged, either in the play or record mode (the **RECORD** key is released if it is in the record mode), the tape will be wound rapidly and, at the same time, you can hear the recorded sound in a high-pitched tone. This helps you to locate the end or beginning of a particular section of the tape. Release the **FAST-F/CUE** or **REWIND/REVIEW**, and normal playback is resumed.

The **PAUSE** switch provides a convenient method of starting and stopping the recorder whenever it is playing or recording. It does not function in fast-forward or rewind mode. To stop tape movement, set **PAUSE** to **IN**. To continue tape movement, set the **PAUSE** switch to **OUT**.

To Record

Connect an optional microphone to the **MIC** jack on the unit; or connect an external source such as a radio, etc., to the **AUX** jack with a suitable patch cord with proper plugs. When both **MIC** and **AUX** jacks are connected, only the **MIC** jack is functional. Set the volume control of the external sound source to a normal listening level.

Press the **RECORD** key. Now the tape starts moving and you are recording. The recording level is automatically set by the CCR-82; you do not have to worry about your recording level being too high or too low. The **VOLUME** control has no effect on the sound.

You can monitor the sound when you record from an auxiliary source. Set the **MONITOR** switch to **IN**. If you are recording from the microphone, do not set **MONITOR** to **IN**. If you do, acoustic feedback (whistling) will take place.

If your microphone has a remote plug, connect it to the **REMOte** jack on the CCR-82. Use the remote switch on the microphone to temporarily stop recording. But be sure that the **PAUSE** switch is set to **OUT**!

To Erase Tape

Each time you make a recording, any previous recording on the tape is automatically erased; thus, the tape may be used for new recording as many times as you wish. For best results, we recommend that computer tapes be bulk erased before reusing them. (Use our Magnetic Bulk Tape Eraser, Radio Shack Catalog Number 44-232.) This will assure that all traces of previously recorded data are removed and will not interfere with the new data.

CAUTION: The bulk tape eraser erases both sides of a cassette. If you want to erase only one side, disconnect the plugs from the **MIC** and/or **AUX** jacks and press **RECORD**.

Accidental Erasure Prevention

Cassettes have a built-in device to automatically prevent erasure of a previous recording. It is a small plastic tab at the back of the cassette. To activate the erase-protect feature, break off the plastic tab with a screwdriver.

There is a tab for each side; be sure you break off the correct tab. (See Figure 1-A.) If you decide you want to record on that cassette after you have broken off the tabs, put a piece of tape over the hole where you brake off each tab, as shown in Figure 1-B.

CAUTION: If you have a cassette with the tabs broken off, don't try to force the **RECORD** key down. You can damage a part of the mechanism.

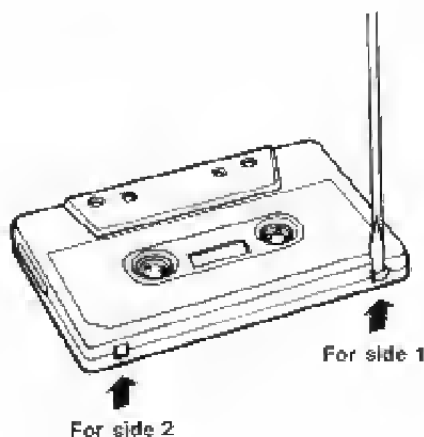

Figure 1-A

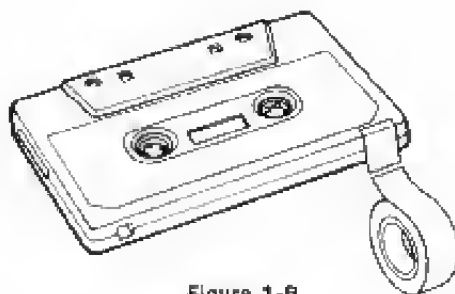
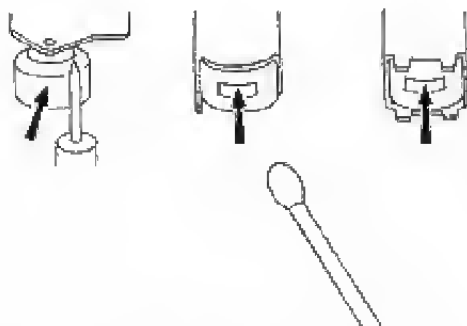

Figure 1-B

Figure 1. Erase Prevention Tabs

Maintenance

With the cassette removed, and with the cassette lid up, press down the **PLAY** key, exposing the erase and record heads and the rubber drive wheel. Clean these points, using a cotton swab moistened with denatured alcohol (not rubbing alcohol) or with a special head cleaning fluid. (Your local Radio Shack store has these items.) To insure good recording and playback results, clean after the first 6 hours of operation (and every 6-8 hours of operation after that). After cleaning, be sure to press the **STOP/EJECT** key, so that these parts may return to their normal operating position for cassette holding. For easy cleaning, we recommend our Cassette Head Cleaner Tape (44-1160).



It is a good idea to periodically demagnetize the tape heads, too. Use one of our Tape Head Demagnetizers. You can clean and demagnetize in one simple operation just by playing our Cassette Demagnetizer Tape (44-631).

If you use the longer, thinner tapes (C-90, C-120, etc.), it is absolutely vital that you keep your recorder clean. Failure to do so will result in poor tape handling, improper auto-stop function, and serious tape wrap-ups. Clean the tape handling parts well and often.

CAUTION:

Do not expose the tape recorder or a cassette to high temperatures or high humidity.

Do not touch the tape heads with screwdrivers or other metal objects, or any magnetic object.

Remove the batteries when the recorder will not be used for more than a month, because battery leakage may damage the unit. Don't leave weak or dead batteries in the recorder.

Specifications

Tape System:	2-track monaural
Tape Speed:	4.75 cm/sec.
Wow and Flutter: (WRMS)	0.28%
Signal-to-Noise Ratio: (Playback/Overall)	50/39 dB
Semiconductors:	2 ICs 5 transistors 4 diodes
Erase System:	DC erasing
AGC Delay Time at Recording:	0.4 sec.
Turn On Time at Record:	0.4 sec.
Record System:	AC bias
Power Requirement:	DC 4 "AA" cells Standard AC via adapter External 12 VDC via adapter
Dimensions:	7-3/32" x 4-11/16" x 1-5/16" (H x W x D) (180mm x 119mm x 33.5mm)
Weight:	1.1 lbs (500g)

Schematic Diagram

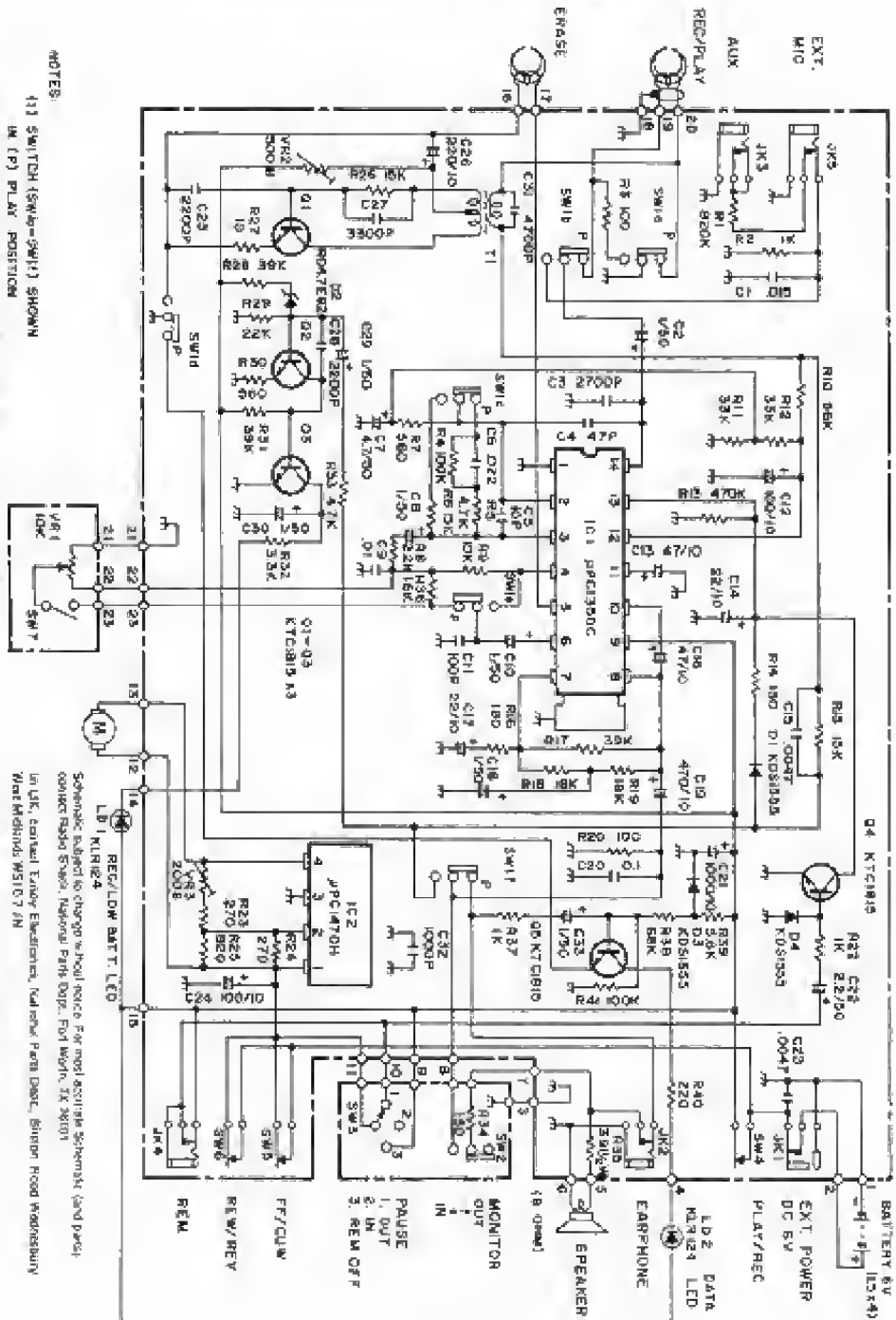

- NOTES:
- (1) SWITCH (SW1-SW11) SHOWN IN (P) PLAY POSITION
 - (2) ALL RESISTANCE VALUES ARE INDICATED IN "OHMS" (R=10³ OHMS, K=10⁴ OHMS)
 - (3) ALL CAPACITANCE VALUES ARE INDICATED IN "UF" (10⁶ UF=1 μF).

Schematic subject to change without notice. For most accurate Schematic (and Parts) contact: Radio Shack, National Parts Dept., Fullerton, CA 92601.

In UK, contact: Evox Electronics, Valence Park Drive, Birton Road, Walsby, West Midlands WS10 7 JN.

In Australia, contact: Tandy Australia Limited, National Parts Dept., 81 Kurrajong Avenue, Mount Druitt, NSW, 2170.