

CTR-80A Computer Cassette Recorder

Catalog Number 26-1206

Radio Shack®

**TRS-80™
MICRO
COMPUTER
SYSTEM**

HARDWARE



CUSTOM MANUFACTURED FOR RADIO SHACK  A DIVISION OF TANDY CORPORATION

The CTR-80A is specially designed for storing your TRS-80 programs and data. It can also be used as a high-quality portable recorder.

Special features include:

- Simple connection to TRS-80 cassette jack (cable supplied)
- Allows TRS-80 to control tape motion while loading or saving programs and data.
- Fast-forward and rewind functions are independent of the TRS-80 — to let you quickly position tape to desired sections.
- LED indicator lights up during input/output operations (also) during fast-forward and rewind.
- Adjustable playback volume to suit the input requirements of your TRS-80 computer.
- Built-in Automatic Level Control (ALC) assures correct record level — you don't have to adjust during output to cassette.

Additional features you'll appreciate if you use the unit for sound, voice or music recordings:

- Battery operation for convenient portable use.
- Automatic shut-off at end of tape during play or record — saves wear on recorder, batteries, and tape.
- During battery operation, LED indicator shows battery condition.

WARNING: TO PREVENT FIRE OR SHOCK HAZARD, DO NOT EXPOSE THIS APPLIANCE TO RAIN OR MOISTURE

CONTROLS AND CONNECTIONS

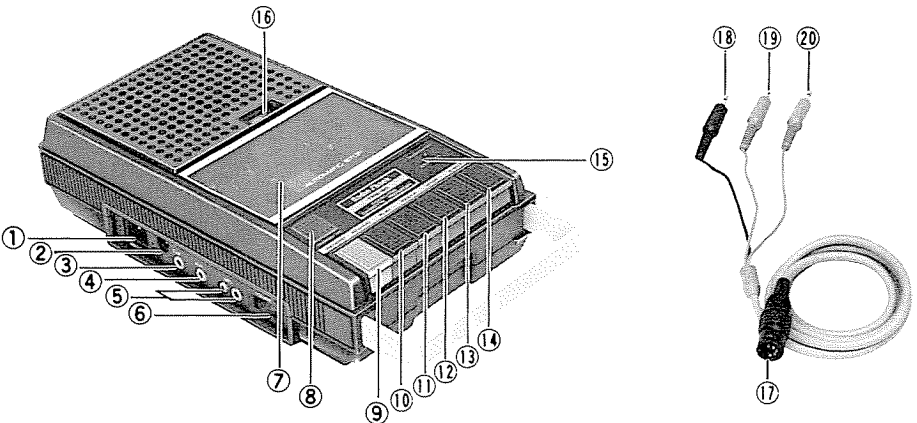

Figure 1. Cassette Unit and Computer Cable.

1. **AC** Power. Connect AC cord here.
2. **DC 6V** power. For use with auto etc. Allows connection to 6V DC power supply (not recommended for computer use).
3. **EAR**phone. Output from tape to computer. Connect black mini plug (18) on computer cable.
4. **AUX**iliary input. Input from computer to tape. Connect gray mini plug (19) on computer cable.
5. **REM**ote control and MICrophone. Allows computer to control tape motion during tape input/output (record/play). Connect gray sub mini plug (20) to REM jack. Other jack is for non-computer use with a remote microphone. Leave empty for computer use.
6. **VOLUME**. Controls level of output from tape to computer. Use the level recommended in your Computer Owner's Manual.
7. Cassette compartment.
8. Built-in condenser microphone. For sound/voice/music recordings. Microphone is disabled when the unit is connected to the TRS-80.
9. **RECORD**. Press together with **PLAY** before starting to save program or data. Tape motion will be computer-controlled.
10. **REWIND**. Press down for rapid rewind (not controlled by computer).
11. **PLAY**. Press down before starting to load program or input data into computer. Tape motion will be computer-controlled.
12. **FAST-Forward**. Press down for rapid tape advance (not controlled by computer).
13. **STOP**. Press down after completion of tape operation.
14. **EJECT**. Press down to eject cassette. Always press **STOP** first.
15. **RECORD/BATTERY**. Lights up during tape operations.
16. **Tape counter**. Helps you position tape to desired program or data file. Press button to reset the counter.
17. Computer cassette plug. Connect to **TAPE** output on computer.
18. Tape output plug. Connect to EARjack on cassette unit.
19. Tape input plug. Connect to AUX jack on cassette unit.
20. Tape control plug. Connect to REM jack on cassette unit.

PREPARATION FOR USE WITH THE TRS-80

Using the computer cable supplied, connect the cassette unit to your computer's TAPE jack. The five-pin DIN plug (17) goes to the computer; the remaining three plugs (18) (19) (20) go to the cassette unit, as explained in Figure 1 on page 3.

The unit should be **STOPped** — press **STOP** to be sure it is.

Connect one end of the AC power cord to the **AC IN** of the recorder, plug other end into a convenient 120V outlet (220/240V AC 50 Hz outlet where the sets are so marked on the bottom for European and Australian models). Connecting the cord to the set automatically disconnects the internal battery circuit. Never leave the cord plugged into an AC outlet when it is not connected to the recorder.

FOR NON-COMPUTER USE

Do not use the computer cable. For AC operation, connect the AC power cord as described previously.

USE WITH BATTERIES (not recommended for computer use)

INSTALLING BATTERIES: Your recorder requires four (4) "C" size 1-1/2 volt batteries. To load batteries, turn the recorder over and open the battery compartment cover. Insert batteries as indicated within compartment, then close the cover.

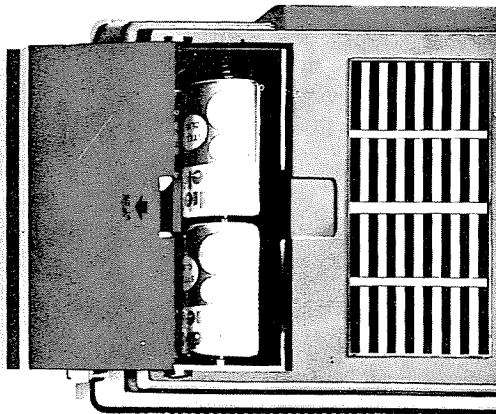

BATTERY CONDITION: The **BATTERY/RECORD** LED indicates the condition of the batteries. When you press the **PLAY** button, if the LED lights brightly, the batteries are OK; if it does not light (or lights only dimly), it is time for new batteries. We recommend Radio Shack Catalog Number 23-581 or 23-551.

DC 6V JACK: You can conserve battery power by using an external source of 6 volts DC connected to this jack.

OPERATION WITH THE TRS-80

For saving your own programs and data, we recommend you use Radio Shack C-20 Certified Cassettes (26-301). These cassettes are leaderless (the entire tape can store information) and individually tested for reliability.

For recording your own programs and data, it's important to start with a blank tape. Unless the tape is new, you should erase the tape before saving new information on it. Radio Shack sells a bulk eraser (Catalog Number 44-210) that does the job quickly and effectively.

INSERTING THE CASSETTE

Press the **STOP** key, then press **EJECT** to open the cassette compartment. Hold the cassette with the side to be played or recorded up and the open tape side toward you. Close the lid. Press **REWIND** and let the cassette rewind all the way to the beginning. When the tape has stopped, press **STOP** again to turn off the drive motor.

To remove the cassette, press **STOP**, then **EJECT**. To play or record on the other side, turn the cassette over so the other label side is up and the tape opening is still toward you. Re-insert the cassette and close the lid.

LOADING A PROGRAM OR DATA FILE FROM TAPE

1. Set the volume to the correct level for your computer (see the computer owner's manual for details). If you have trouble loading programs or inputting data, try adjusting the volume.
2. Be sure the tape is positioned to just before the start of the recorded program or data. Usually, this means the tape should be rewound all the way (or positioned using the counter, as explained in the Note later on).
3. Before the computer is ready to load the program or input the data, press **PLAY** on the recorder. The computer will control the tape motion. While the computer is actually receiving data from the recorder, the LED will be lit.
4. When the computer has completed the tape operation, press **STOP**.

SAVING A PROGRAM OR DATA FILE ON TAPE

1. Insert a blank (new or bulk-erased) tape, and rewind it to the beginning of the tape (if using tape with a leader, be sure to advance it past the leader to the beginning of the recording tape).

2. Before the computer is ready to save the program or data, press **RECORD** and **PLAY** together. Both keys should remain "down". You do not need to adjust the volume setting; the cassette unit does that automatically during record operations.
3. You can now save the program or data in tape. The computer will turn the tape on and off as necessary to complete the operation.
4. When the operation is complete, press **STOP** on the recorder.

Note: It is possible to record two or more programs or data files on one side of a tape. However, this takes a little extra care and attention on your part. First rewind the tape and reset the tape counter. Then keep a written account of the counter reading where each program or data file starts.

When you are ready to load in a particular program or data file, rewind the tape, reset the counter, then use fast-forward or rewind to position the tape to just ahead (one digit) of the desired tape section.

OTHER USES FOR THE RECORDER

The CTR-80A will also serve as an excellent general-purpose recorder. Operation is quite similar to that described above, only the unit is not connected to the TRS-80, and is totally under manual control.

TO PLAYBACK

1. Rewind the tape by pressing the **REWIND** key.
2. Press the **STOP** key when you reach that section of the tape you wish to play.
3. Press the **PLAY** key and adjust the **VOLUME** control for the desired sound level from the speaker.
4. To stop playback, press the **STOP** key. If you want, let the tape play to the end and the unit will automatically shut off the power.
5. When playing back a recorded tape, make sure the **RECORD** key is not pressed; otherwise the recorded tape will be erased.
6. For private listening, connect the earphone to the **EAR**phone jack on the side of the recorder.

TO RECORD

RECORDING WITH BUILT-IN CONDENSER MICROPHONE:

1. Press the **RECORD** and **PLAY** keys simultaneously and recording will start.
2. During recording, a built-in Automatic Level control (ALC) circuit automatically sets the proper recording level.
3. The built-in condenser microphone is highly sensitive and will pick up sound from practically any distance in a normal size room.
4. At the completion of the recording press the **STOP** key. If the end of the tape is reached while recording, the unit will shut off automatically.
5. As you record, the **BATTERY/RECORD** LED will flash with peaks of sound. This will remind you that you are recording.

RECORDING WITH EXTERNAL MICROPHONE:

Connect an optional microphone to the **REM**ote/**MIC**rophone Jacks, this automatically disconnects the built-in microphone. Recording procedures are the same as for recording with the built-in microphone. Use the remote switch on the microphone to temporarily stop recording.

RECORDING FROM RADIO OR PHONOGRAPH:

1. Connect signal from the external source into the **AUX** jack (use a suitable patch cord with proper plug).
2. Set the Volume control of the external sound source to a normal listening level.
3. Follow the instructions noted above.

NOTE: When both **MIC** and **AUX** jacks are connected, only **MIC** jack is functional.

REWIND AND FAST-FORWARD KEYS

1. To rewind tape, press the **REWIND** key.
2. To move tape rapidly in a forward direction, press the **FAST-Forward** key.
3. IN either case, to stop tape travel, press the **STOP** key.

TO ERASE TAPE

To change recordings, merely record over the old recording. The old recording will automatically be erased and the new one put on the tape. If you do want to erase a cassette, or just a portion of a recording, insert the special Dummy Plug (provided) into the **MIC** jack. Then, operate the CTR 80A just as though you were recording. As the tape moves, it will be erased clean (no sound pick up from Mic when using this Dummy Plug).

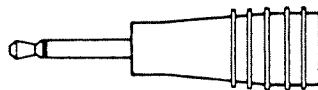

Dummy Plug

ACCIDENTAL ERASURE PREVENTION

Cassettes have a built-in device to automatically prevent erasure of a previous recording. It is a small plastic tab at the back of the cassette. To activate the erase-protect feature, break off the plastic tab with a screwdriver.

There is a tab for each side; be sure you break off the correct tab. If you do want to record again on that cassette, put a piece of tape over the hole where you broke off the tab.

CAUTION: If you have a cassette with the tabs broken off, don't try to force the **RECORD** key down. You can damage a part of the mechanism.

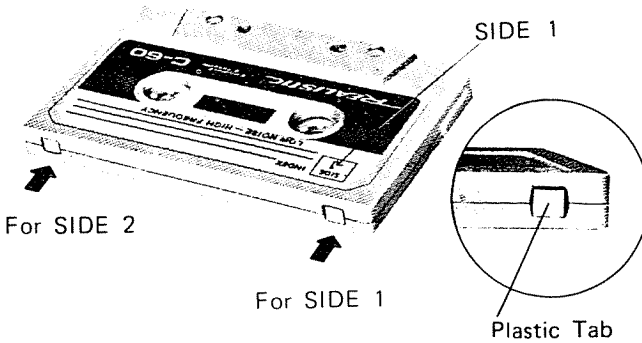

MAINTENANCE

To keep your recorder performing up to its capabilities as a data storage device, it is very important that you clean the head and capstan regularly. The actual time interval between maintenance depends on how much you use the unit. If you begin having trouble loading data or programs, it's probably time to give the unit a thorough cleaning. As a general rule, clean the unit every 10-20 hours of operation.

CLEANING PROCEDURE

With batteries and cassette removed, and with cassette lid up, press down the **PLAY** key, exposing the erase and record heads and the rubber drive wheel. Clean these points, using a cotton swab moistened with denatured alcohol (not rubbing alcohol) or with a special head cleaning fluid. Your Radio Shack store has these items. After cleaning, be sure to press the **STOP** key, so that these parts may return to their normal operating position for cassette loading. For easy cleaning, we recommend our Cassette Head Cleaning Cartridge, Catalog Number 44-1160.

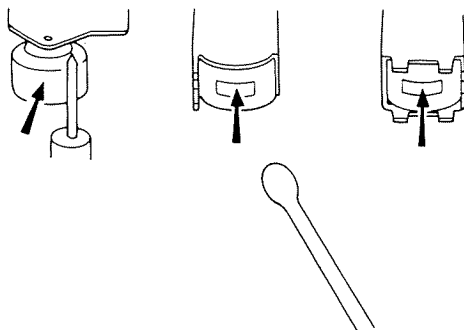

Demagnetizing the Heads

You should also demagnetize the heads periodically. Again, how often depends on how much you use the unit. We suggest that you demagnetize the head after every 10-20 hours of operation.

For this operation, you'll need the Radio Shack Tape Head Demagnetizer, Catalog Number 44-211.

LIMITED WARRANTY

For a period of 90 days from the date of delivery, Radio Shack warrants to the original purchaser that the computer hardware described herein shall be free from defects in material and workmanship under normal use and service. This warranty is only applicable to purchases from Radio Shack company-owned retail outlets and through duly authorized franchisees and dealers. The warranty shall be void if this unit's case or cabinet is opened or if the unit is altered or modified. During this period, if a defect should occur, the product must be returned to a Radio Shack store or dealer for repair, and proof of purchase must be presented. Purchaser's sole and exclusive remedy in the event of defect is expressly limited to the correction of the defect by adjustment, repair or replacement at Radio Shack's election and sole expense, except there shall be no obligation to replace or repair items which by their nature are expendable. No representation or other affirmation of fact, including, but not limited to, statements regarding capacity, suitability for use, or performance of the equipment, shall be or be deemed to be a warranty or representation by Radio Shack, for any purpose, nor give rise to any liability or obligation of Radio Shack whatsoever.

EXCEPT AS SPECIFICALLY PROVIDED IN THIS AGREEMENT, THERE ARE NO OTHER WARRANTIES, EXPRESS OR IMPLIED, INCLUDING, BUT NOT LIMITED TO, ANY IMPLIED WARRANTIES OF MERCHANTABILITY OR FITNESS FOR A PARTICULAR PURPOSE AND IN NO EVENT SHALL RADIO SHACK BE LIABLE FOR LOSS OF PROFITS OR BENEFITS, INDIRECT, SPECIAL, CONSEQUENTIAL OR OTHER SIMILAR DAMAGES ARISING OUT OF ANY BREACH OF THIS WARRANTY OR OTHERWISE.

RADIO SHACK  **A DIVISION OF TANDY CORPORATION**

U.S.A.: FORT WORTH, TEXAS 76102
CANADA: BARRIE, ONTARIO L4M 4W5

TANDY CORPORATION

AUSTRALIA

280-316 VICTORIA ROAD
RYDALMERE, N.S.W. 2116

10A0

BELGIUM

PARC INDUSTRIEL DE NANINNE
5140 NANINNE

U. K.

BILSTON ROAD WEDNESBURY
WEST MIDLANDS WS10 7JN

PRINTED IN HONG KONG
606 - 920 - 0 - 09