

CRC ERROR! TRACK LOCKED OUT!
A Better Disk Data Separator for the TRS-80
From PERCOM DATA CO.

The disk read data separation arrangement in the TRS-80 Expansion Interface uses the internal data separator in the 1771 Disk Controller which is a part of the Expansion Interface. Use of the 1771 internal data separator is NOT RECOMMENDED by the 1771 manufacturer! The following note appears in the middle of page 17 of the Western Digital FD1771 data sheet:

NOTE: Internal data separation may work for some applications. However, for applications requiring high data recovery reliability, WDC recommends external data separation be used.

If you are using TRSDOS this adapter will not solve all of your disk problems! TRSDOS 2.1 has many software bugs which cause all manner of disk problems. If you must use TRSDOS the Percom PATCH-PAK diskette solves some of the more serious problems we are aware of and permits you to use the extra storage space available on the Percom disk drives. Instead of TRSDOS we recommend NEWDOS+ which was written by Apparat and is available from Percom. NEWDOS is a super improvement over TRSDOS!

Although considerably different in structure than either TRSDOS or NEWDOS we also recommend the Percom MICRODOS. It takes advantage of the faster access time and extra storage capacity available on the Percom disk drives.

To order any of the items mentioned call the Percom Toll-Free order number 1-800-527-1592. If you have a technical question call (214) 272-3421 between 9AM and 5PM Central time.

NOTICE

This equipment has been fully tested to verify function and reliability and the information and instructions contained herein has been thoroughly checked for accuracy however, Percom Data Company is not responsible for damages either direct or consequential which may arise as the result of installation and use of this equipment.

If the purchaser is unable or unwilling to follow the attached instructions for the installation of this equipment, return the sealed envelope containing the Data Separator adapter within 10 days for a full refund. Units returned in which the seal has been broken will be charged a \$7.50 retest and restocking charge.

TRSDOS and TRS-80 are registered trademarks of Radio Shack

WARNING!

Disassembly of Radio Shack Computer equipment voids your warranty! This 90 day period is provided by Radio Shack to give the consumer an opportunity to be thoroughly convinced that the equipment purchased is completely operational with no defects. It is recommended that you thoroughly check your Expansion Interface and exercise your warranty rights if necessary. A Data Separator will not help problems caused by a defective Expansion Interface!

STATIC ELECTRICITY:

The solid state devices contained in the Expansion Interface are very sensitive to static electric charges. You should fill these simple requirements before going any farther.

1. Wear clothes that do not have static problems.
2. Choose a place that is NOT carpeted (such as the Dining Room).
3. Clear a working area (such as the Dining Room table).
4. Gather all materials and tools so that a trip to another part of the house is unnecessary. (Note tools and materials needed: medium phillips screwdriver, bottle of red nail polish, a flat nail file, Data Separator Card, and the Expansion Interface.)

INSTALLING THE DATA SEPARATOR:

1. Disconnect all cables from the Expansion Interface and take it to your WORKING AREA.
2. The entire system should be OFF and both Power Supplies unplugged.
3. Position the Expansion Interface on the table in front of you facing the back with the power cables coming from the box on your left.
4. Remove the three phillips-head screws from the Power Supply Compartment cover. (This is the cover on top to your left.)
5. Remove both Power supplies and place them to the left of the BOX (one power cable will still be connected).
6. Place the Interface upside down with the Power switch facing you. (The TRS-80 emblem should be to your left.)
7. Remove the six (6) screws holding the bottom to the top.
8. Remove the gray plastic bottom cover.
9. Locate 1771 chip (see Diagram).
10. Take the red nail polish and put a mark on top of the chip over pin 1 end (denoted by a groove in the end of the chip, see Diagram).

11. Put a red mark on the Printed Circuit Board on the same end as before (this will denote the position after the chip is removed).

WARNING! READ INSTRUCTIONS 12 - 17 BEFORE GOING ON!

The next step is very important! If you break any of the pins off of your 1771 chip it will be virtually worthless!

12. Gently insert the nail file between the 1771 chip and socket (see Diagram) then pry that side up a little.
13. Withdraw the nail file and insert into the opposite side. Then pry up a little.
14. Repeat 12 and 13 until the 1771 lifts out of the socket easily.
15. Locate the 40 pin socket on your Data Separator Card. Locate pin 1, see Diagram.
16. Take the Data Separator Card in one hand and position the 1771 in the socket (pin 1 to pin 1, see Diagram), holding it in with your thumb. Then use both hands with both thumbs on top of the chip and press firmly. The chip should snap into place. Then examine the chip to check for any bent pins. Note: If you bend any pins, remove the chip as instructed in step 12-14. Straighten the pins and try again.
17. Plug the card into the socket on your Expansion Interface noting the red marks are still in the same position. If you can take the Data Separator Card in your fingers and lift the right end of the Expansion Interface several inches off the table, the card is plugged in far enough. See Diagram.

WARNING!

This is your chance to recheck everything you have done so far! A mistake at this point will mean disaster! Check Pin ONE (1) of the chip, Pin ONE (1) of the Data Separator Card and Pin ONE (1) on the Expansion PC Board to confirm their position is correct.

18. Replace the gray plastic bottom and the six (6) screws. (Don't over tighten screws) Note: The longest screws go in the holes closest to you, the medium screws go in the next set of holes. The shortest screws go in the holes farthest from you.
19. Turn the Expansion Interface over again to its original position.
20. Place the Expansion Interface Power Supply inside the compartment.
21. Next, place the TRS-80's Power Supply inside the compartment.
22. Route the three unconnected cords (two AC powercords, one DIN cable) out of the case. Be sure to seat them in the cutouts provided in the case.
23. Replace the compartment cover. Don't over tighten the screws or you might damage the case.
24. Replace the Interface in the system.

Your installation is now complete.

CHECK-OUT PROCEDURE:

1. After reconnecting all Interface cables, boot up the DOS.
2. Format and verify a disk.

WHAT TO DO IF IT DOES NOT WORK:

1. TURN THE ENTIRE SYSTEM OFF.
2. Recheck all the cables.
 - a) Disk Drive cable
 - b) Interconnection between Computer and Interface
 - c) Video Input
 - d) computer power supply input
 - e) Did you have the right A.C. plugs connected (2 from interface, 1 from monitor, 1 from each Disk Drive).
3. Did you have all the power switches on?
 - a) Disk Drive
 - b) Computer
 - c) Interface
 - d) Monitor.
4. Did you get the right system Disk?
5. Go back to the beginning and start all over!
6. After you have tried this procedure and you still have problems you may want to call PERCOM TECHNICAL SUPPORT. The number is (214) 272-3421.

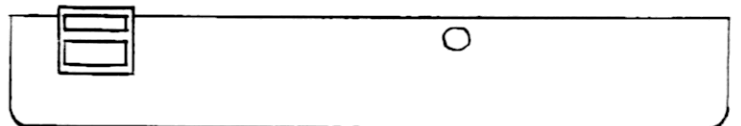
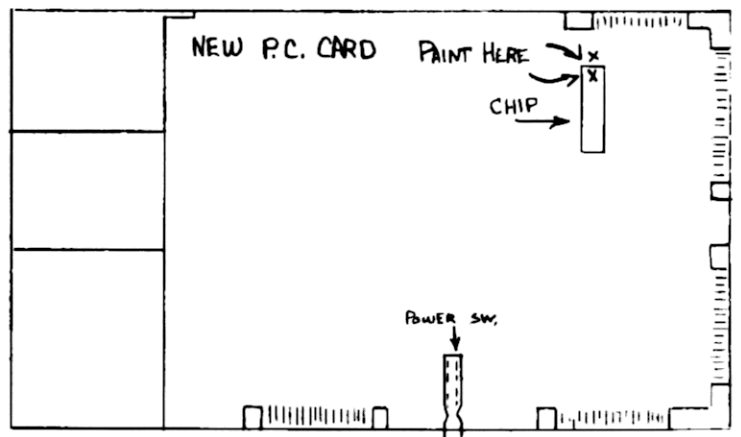
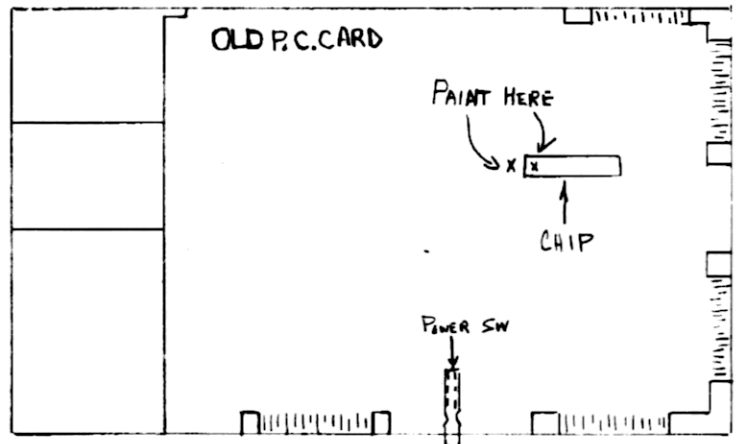
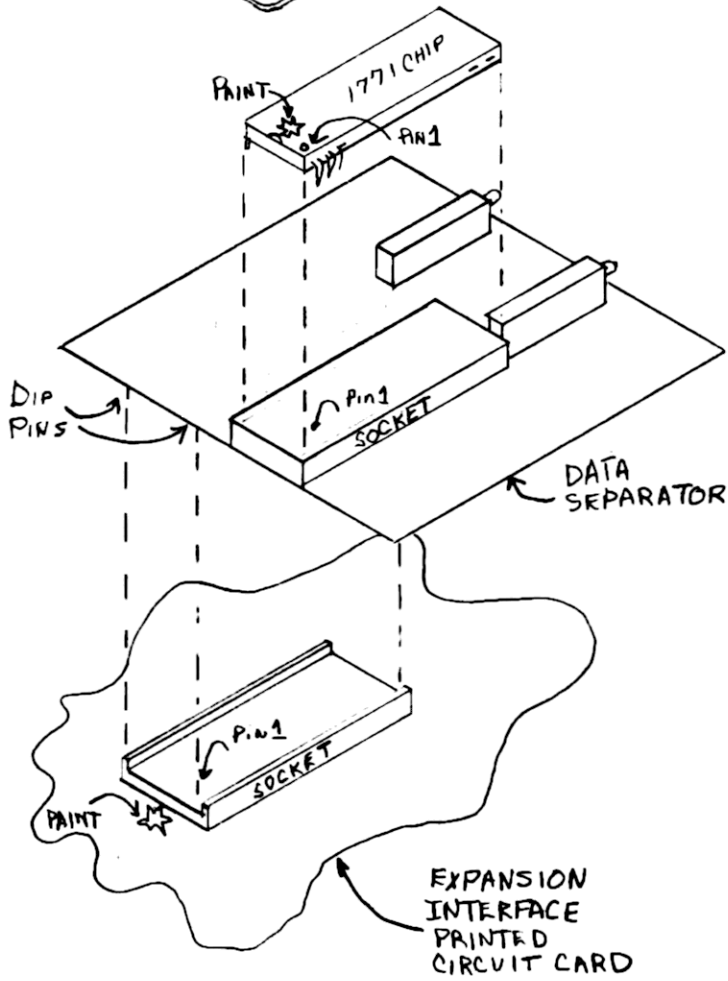
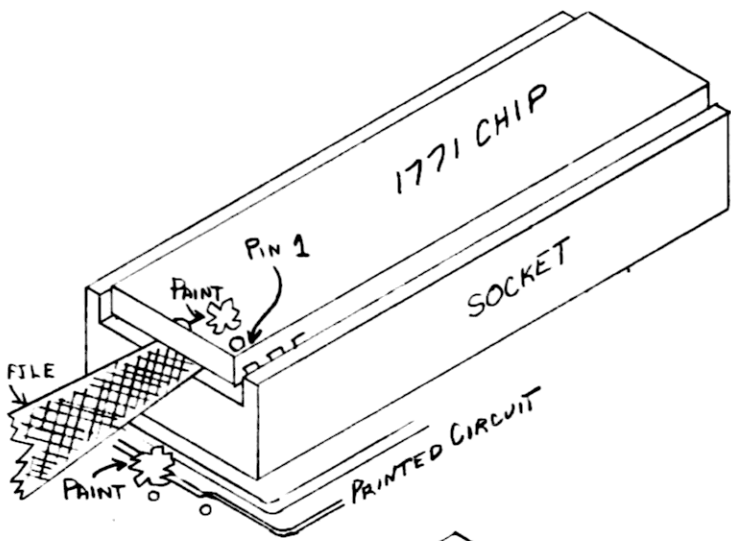

PERCOM DATA CO. INC.
211 N. Kirby
Garland, Tx 75042
(214) 272-3421

STATEMENT OF LIMITED WARRANTY

For a period of 90 days from the date of delivery, Percom Data Co. Inc. warrants to the original purchaser that the computing **equipment** described herein shall be free from defects in material and workmanship under normal use and service. During this period, if a defect should occur, the equipment must be returned to the Percom Data Co. Service Facility at the above address for repair. The purchaser must prepay all shipping and insurance charges and must supply proof of purchase from Percom Data Co. or an authorized Percom dealer or distributor. Purchaser's sole and exclusive remedy in the event of defect is expressly limited to the correction of the defect by adjustment, repair or replacement at Percom's election and sole expense, except there shall be no obligation to replace or repair items which by their nature are expendable. No representation or other affirmation of fact, including, but not limited to, statements regarding capacity, suitability for use, or performance of the equipment, shall be or be deemed to be a warranty or representation by Percom Data Co. Inc., for any purpose, nor give rise to any liability or obligation of Percom Data Co. Inc. whatsoever.

EXCEPT AS SPECIFICALLY PROVIDED IN THIS AGREEMENT, THERE ARE NO OTHER WARRANTIES, EXPRESSED OR IMPLIED, INCLUDING, BUT NOT LIMITED TO, ANY IMPLIED WARRANTIES OF MERCHANTABILITY OR FITNESS FOR A PARTICULAR PURPOSE AND IN NO EVENT SHALL PERCOM DATA CO. INC. BE LIABLE FOR LOSS OF PROFITS OR BENEFITS, INDIRECT, SPECIAL, CONSEQUENTIAL OR OTHER SIMILAR DAMAGES ARISING OUT OF ANY BREACH OF THIS WARRANTY OR OTHERWISE.