

Choosing the Right Capacitor

We experimenters must decide which type of fixed-value capacitor is best for new designs or when repairing a piece of radio equipment. The wrong capacitor can spoil circuit performance, or it might not survive in the circuit environment we expose it to. Capacitor selection is far from casual, even if we understand the intrinsic nature of this rather ordinary component. I will explain the characteristics of some common capacitors and offer some advice concerning their use.

■ Ceramic Capacitors

Ceramic capacitors come in many shapes and sizes. The most common form is the disc ceramic unit with pigtailed. These capacitors are used principally for bypassing and coupling (blocking) from audio through VHF. An important trait they exhibit is low internal inductance. An ideal capacitor, no matter what style it might be, would have no internal inductance (X_L), resistance, or loss. It would present a pure capacitance. However, the manufacture of an ideal capacitor remains to be accomplished.

Excessive inductance spoils the ability of the capacitor to function as a bypass element, especially as the operating frequency is raised. At VHF, for example, it may act more like an RF choke than a capacitor. Fortunately, disc ceramic capacitors have minimal internal inductance. Hence, they are suitable for most RF applications through 60 MHz. Their pig-tails introduce unwanted inductance at the higher frequencies. Therefore, those leads must be kept as short as practicable. The disc capacitor illustrated in Figure 1 is available as a general-purpose (Z5U) type that is useful for circuit bypassing and for coupling between circuits. Its actual capacitance may be close to the marked value at +25°C, but it can change $\pm 20\%$ from -55°C to +85°C. Therefore, the general purpose disc capacitor should not be used in critical circuits such as filters, tuned circuits, oscillators and VFOs.

Special temperature-stable disc ceramic capacitors are available. They are identified as NP0 (NP zero) units. These usually have a black dot on the body. Likewise with the

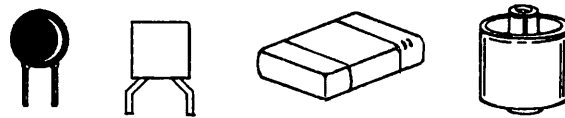
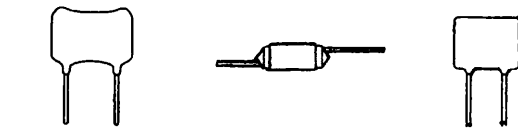

FIGURE 1



Outlines, L to R top row, are for disc ceramic, square ceramic, SMD ceramic and transmitting ceramic. Shown in the bottom row, L to R, are silver-mica, polystyrene and polyester capacitors.

older tubular (dog bone) NP0 ceramic capacitors. They are ideal for use in the aforementioned critical applications. An NP0 capacitor is rated for a $\pm 5\%$ change over the temperature range listed above for general-purpose capacitors. NP0 capacitors are widely used in oscillator circuits to minimize long-term frequency drift.

General-purpose and temperature-stable ceramic capacitors are available in other formats too. Some are square or rectangular. The CN series devices are ultra stable and are made by Phillips Corp. The "CW" prefix indicates temperature stability on par with NP0 units. General-purpose capacitors of this species are marked "CZ."

Surface-mount (SMD) monolithic ceramic capacitors or "chips" are available also. They are tiny and rectangular in shape. There are no pigtailed. These devices have a metal coating at each end so that they can be soldered directly to the PC-board conductors. This virtually eliminates unwanted inductance. These capacitors are widely used at VHF and above. They are also available as NP0 and general-purpose units.

Still another ceramic capacitor style is manufactured for high-power, high-voltage use, such as in transmitters. These have been called "barrel capacitors" for many years. They are rated as high as 15,000 volts. Type 858S has a temperature tolerance of $\pm 20\%$, whereas types 850S and 857 have a $\pm 10\%$ temperature tolerance. Types 8540 and 8550 are NP0 units.

■ Silver-Mica and Polystyrene Capacitors

In the order of temperature stability and minimum internal inductance are polystyrene and silver-mica capacitors. Generally, polystyrene capacitors closely follow the traits of NP0 ceramic capacitors. They are useful up to approximately 15 MHz. A third choice for temperature stability is the silver-mica, or dipped silver-mica capacitor. These capacitors have very close tolerances respective to their marked values. The D type made by CDE is rated at 0.5 pF of the marked value. Type J is within $\pm 5\%$ of the marked value. These capacitors have a

high resistance to the effects of humidity and moisture. They are excellent for use in RF filters, low- and medium-frequency oscillators and tuned circuits. See Figure 2 for circuit examples. Polystyrene capacitors are similarly tight with respect to their marked values and are resistant to moisture.

■ Capacitor Q is Important

The term "Q" stands for quality factor. It is a measure of how lossy or AC-resistive a capacitor or coil may be. In tuned circuits the selectivity improves with increased loaded Q. A "loaded" circuit is one that is connected to its related circuit components, such as an antenna and an RF-amplifier in a receiver front end. The unloaded Q is always higher than the loaded Q.

The capacitors we choose for critical circuits of this type must have a high Q in order to avoid degrading the overall circuit Q. This is especially important in VFOs, fixed-frequency oscillators, RF filters and tuned circuits. NP0 ceramic, polystyrene and silver-mica capacitors all have high Q factors. A polystyrene capacitor, for example, may have a Q as high as 1000. The Q of tuned circuits in most equipment is seldom greater than 300. However, extremely high Q (1000 or greater) is possible with carefully designed helical resonators and resonant cavities.

■ Other Capacitor Types

Mylar, polypropylene, polyester, tantalum, and electrolytic capacitors are common-

FIGURE 2

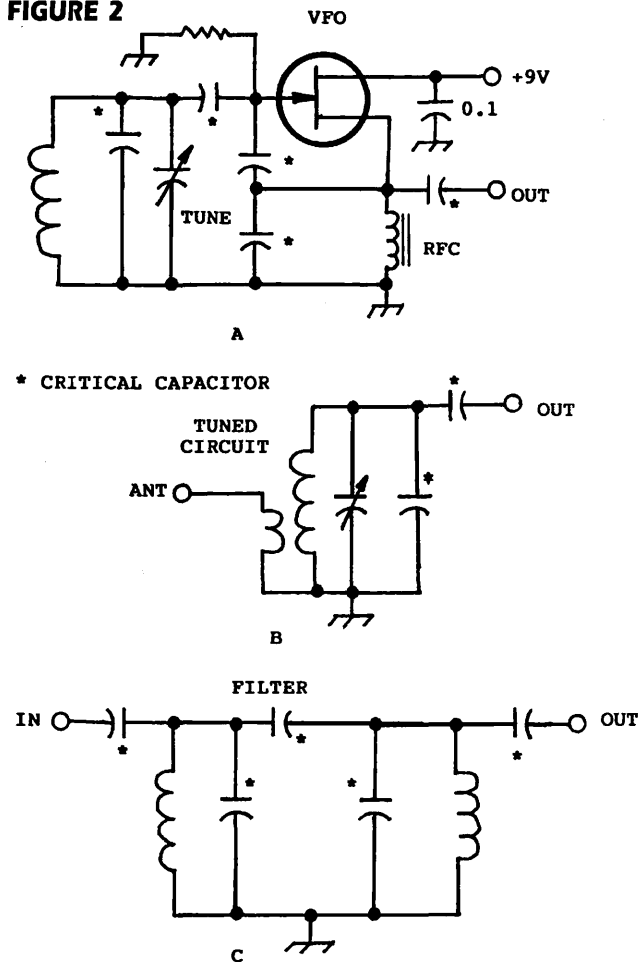

Examples of circuits that require capacitors with close-value tolerances, temperature stability and high Q. A VFO is shown at A. At B is a parallel tuned resonant circuit. The filter at C uses silver-mica or polystyrene capacitors.

place in the equipment we buy. Most of the foregoing varieties are used for audio, VLF, LF, and MF applications. Therefore, I won't dwell on their traits.

Electrolytic capacitors are used primarily in power-supply filter circuits and for bypassing and coupling in audio circuits.

High-capacitance tantalum capacitors have low internal inductance and they are small in size. This makes them useful in RF bypass and coupling circuits below approximately 1 MHz.

■ Voltage Ratings

Capacitor longevity is dependent upon it having a maximum voltage rating greater than the highest voltage in the circuit where it is used. It is prudent to allow plenty of safety factor. For example, I use 50-volt ceramic capacitors in my 12-VDC circuits. I prefer 35-volt electrolytic and tantalum capacitors for 12-volt circuits, even though 16- or 25-volt

capacitors should be okay. I use 0.01- μ F, 1000-volt ceramic capacitors for bypassing the 120-volt AC line inside my equipment cabinets. Capacitors with a 600-volt rating may also be used, but I am a coward: I detest blown fuses and the odor of charred components!

■ Closing Remarks

Space doesn't permit an in-depth treatment of capacitors and their applications. The tips provided in this article should help you to avoid errors when you select capacitors for that next workbench project. You will save money if you do your shopping in surplus electronics catalogs and at radio flea markets.

Having a digital capacitance meter in your shop is essential when you need to know the values of unmarked capacitors, or those with strange markings. The numbers on silver micas can be misleading. For example, a unit marked "150J" is a

15-pF rather than a 150-pF capacitor. On the other hand, a 201J is a 200-pF capacitor. Confusing, eh?

AMPLIFILTER™

- Improves shortwave reception.
- Use with any antenna, any receiver.
- Front panel control of all functions.

New! Amplifilter™ gives 20 db preamplifier gain or 20 db attenuation and cuts out overload and crossmodulation from local AM broadcast and TV/FM stations. It has a broadband .1 to 1000 MHz amplifier, an attenuator, a 3 MHz highpass filter, and a 30 MHz lowpass filter. They are individually selectable by front panel switches, one at a time or in any combination.

Model PA-360 Amplifilter™ \$79.95 + \$6 shipping/handling in U.S. & Canada. For 12v DC. Model PS-90 AC adapter \$9.95.
California residents add sales tax.

Send for **FREE** catalog that shows our complete line of antennas, pre-amplifiers and filters.

PALOMAR ENGINEERS

BOX 462222, ESCONDIDO, CA 92046
Phone: (619) 747-3343; FAX: (619) 747-3346
e-mail: 75353.2175@compuserve.com

Motron 310 Garfield St Suite 4
PO Box 2748
Eugene, Oregon 97402

<http://www.motron.com>

DTMF DECODER

The TDD-8X features a large 8-digit LED display and decodes all 16 DTMF digits. The 104 character memory is viewed, without loss of data, by scrolling either left or right. Although a computer is not required, the serial ASCII output allows for automatic logging of decoded number groups. ToneLog™, our IBM/Compatible logging software, is included with each TDD-8X purchase.

TDD-8X Assembled & Tested PCB \$59.00 **PMK-1 Plastic Mounting Kit \$15.00**
CAB-1 Audio & Computer Cables 20.00 **PS-12 12VDC AC Power Adaptor 10.00**

Visa, MasterCard, American Express, Discover and Government Purchase Orders accepted.
COD on Cash or Money Order basis only.

Minimum Government Purchase Order: \$99.
S/H: \$8 USA; \$11 Canada; \$16 Foreign COD: \$5.
Premium Shipping available at additional charge

\$59.00

Plus S/H

Info: (541) 687-2118 **Orders: (800) 338-9058** Fax: (541) 687-2492

Choosing the Right Capacitor

Have you been confused about selecting the correct capacitor for a particular application? If so, you aren't alone in your moments of indecision! As the state of the art advances, we find new types of capacitors listed in our catalogs each year.

Gone are the days when the tubular paper capacitor, large mica capacitors, and electrolytic capacitors were all that we had to work with. Things aren't quite so simple for a nontechnical person these days! Let's examine some of the more common capacitors we must work with.

Disc Ceramics

It isn't necessary to use special capacitors in most audio circuits, but when we deal with RF (radio frequency) circuits, the matter becomes one of concern, respectively to using effective capacitors.

The disc ceramic unit is generally the best choice for bypassing and coupling circuits at RF. Why is the disc ceramic so good? It is because it has minimum unwanted inductance along with the desired capacitance.

Unwanted inductance (X_L , or inductive reactance) is caused by the pigtail leads on the capacitor. There can also be some internal X_L , depending upon how the component is made. If we were to short-circuit the capacitor leads we would find that the leads and the capacitor formed a tuned circuit at some frequency. This can be checked with a dip oscillator.

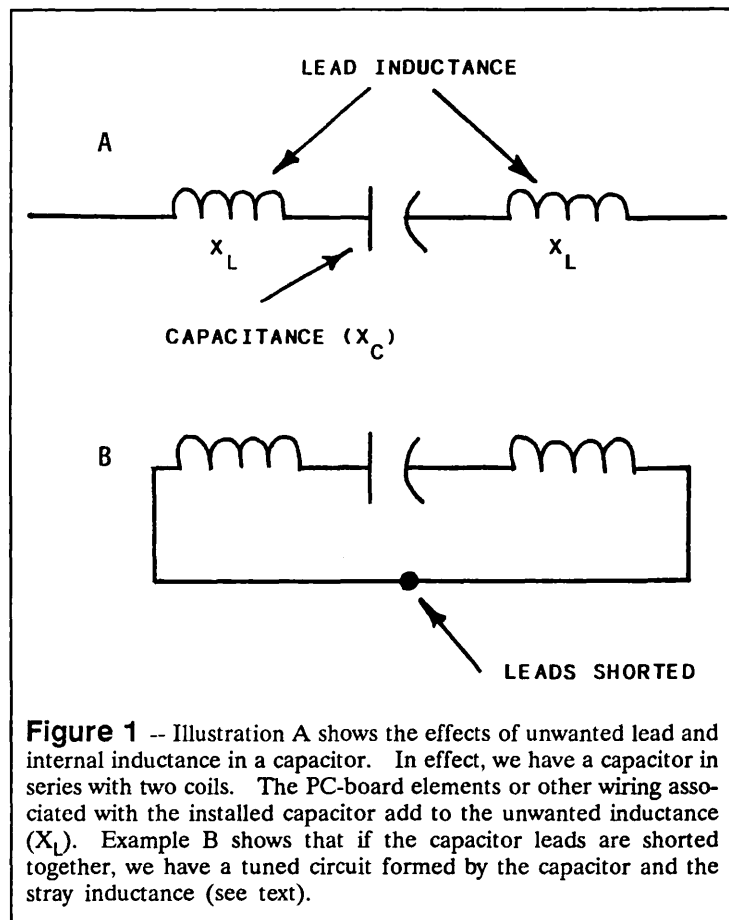

Figure 1 -- Illustration A shows the effects of unwanted lead and internal inductance in a capacitor. In effect, we have a capacitor in series with two coils. The PC-board elements or other wiring associated with the installed capacitor add to the unwanted inductance (X_L). Example B shows that if the capacitor leads are shorted together, we have a tuned circuit formed by the capacitor and the stray inductance (see text).

But, disc ceramics have the least unwanted or parasitic inductance of the many types available. The notable exception is the monolithic chip capacitor. It has no leads. It is soldered directly to the PC-board pads by means of metalized end strips on the capacitor body. Chip capacitors are used mainly at VHF and UHF, where stray inductance can't be tolerated.

The common disc ceramic is suitable for use from DC into the lower VHF spectrum. The important consideration is to keep the leads as short as practicable when you solder them into your circuit.

The unwanted X_L tends to negate the effectiveness of the capacitor, especially as the operating frequency is increased. The stray inductance is in series with the capacitance (see Figure 1) and this ruins the function of the capacitor.

In a severe case it is as though the capacitor was not there at all, especially in a bypass application. Ineffective bypassing can cause a circuit to self-oscillate and become unstable. If the emitter of a bipolar transistor or the source of a FET amplifier is poorly bypassed (owing to excessive X_L), the stage will have low gain. This is caused by what is known as degenerative feedback. Therefore, it is wise to keep the capacitor leads as short as you can make them.

A similar event occurs when there is excessive stray inductance in a coupling circuit between amplifier stages (blocking capacitor). If the X_L is too great, it will be difficult for the RF signal to pass through the capacitor from one amplifier stage to the next. Again, keep those leads short.

Large mylar and polyester capacitors are not suitable in RF circuits. They have considerable internal inductance along with that caused by the pigtails. They are fine for audio and DC circuits where stray inductance is too minimal to worry about.

Silver-Mica Capacitors

There are two kinds of silver-mica capacitor. One is the older style that has a square or rectangular molded-plastic case. The case has a red color.

The units that have brown cases are not silver-mica. They are also mica capacitors, but aren't as temperature-stable as the silver-mica ones.

Modern silver-micas are called "dipped" silver-micas. The outer insulation is brown in color and they are much smaller than the older units. The capacitance value is printed on the case, whereas the old silver-micas used a color code of dots to signify the value.

Most silver-mica capacitors perform well into the lower VHF region if the leads are kept short. They are slightly more inductive than are disc ceramics, but they may be used for coupling and bypassing.

The internal capacitor plates are coated with silver in order to improve the conductivity of the plates. This helps them to work more effectively at the higher frequencies. The silver increases the capacitor Q (quality factor), and this is important if a tuned circuit requires high Q.

An example of this principle is when we use a high-Q slug-tuned coil with a fixed-value capacitor in parallel or in series with the coil. A capacitor with low Q can negate the high Q of the coil. This results in a broadly resonant tuned circuit, whereas we may require a narrow response in order to reject RF energy from frequencies above and below the desired frequency.

Stable Capacitors

The ability of a capacitor to maintain its manufactured value in an environment of changing temperature is vital in oscillator circuits. Capacitance changes cause frequency drift. This is especially annoying in a receiver or transmitter tuned oscillator.

Perhaps the best capacitor you can use in an oscillator or tuned filter is the NPO (last digit is a zero) disc ceramic. These capacitors cost slightly more than conventional disc ceramics, but they stay put very nicely as the ambient temperature around them, plus any internal heating caused by RF current, varies. I use them in all of my VFO (variable frequency oscillator) circuits. I use them also in high-order crystal overtone oscillators, where frequency drift can, and does, occur.

Your second option is to use polystyrene capacitors if you can't locate any NPO capacitors. The polystyrene capacitor is entirely acceptable up to approximately 30 MHz in an oscillator circuit. They are nearly as temperature-stable as NPO ceramics. They are, however, somewhat more inductive (X_L again!), so it's important to keep those capacitor pigtailed as short as you can.

My experience has proven that they are less prone to capacitance change than are disc ceramics, respective to internal heating from RF currents. This is because they have greater capacitor-plate area within them.

Silver-micas may also be used in oscillators, but they are rather unpredictable in terms of stability. Some will exhibit positive drift (increased capacitance) while others from the same manufacturer's batch will show negative drift (decreased capacitance).

If you have several silver-micas of the desired value, keep substituting them in your circuit until you find a group of capacitors that provide stable oscillator operation. This cut-and-try method is tedious, but it pays off.

Stable, high-Q capacitors are needed also in audio filters. Polystyrene is an excellent choice in this application, but mylar capacitors are acceptable also. Silver-micas could be used in audio filters, but they do not generally have high enough capacitance values for audio work.

Capacitor Voltage Ratings

Be cautious when ordering your capacitors. The voltage rating is important if the capacitor is to survive in your project. The miniature 50- or 100-volt DC capacitors are fine for circuits that operate from 12 or 24 volts DC. They occupy far less room on a PC board than do the larger 600-volt types.

Always allow a safety margin of twice the circuit operating voltage when dealing with DC. For AC applications, such as the bypassing of the 120-volt AC line, you must take into account the peak-to-peak AC voltage. In other words, 120 volts RMS (root mean square) is what you take from the wall outlet. The peak-to-peak value of this voltage is 2.828 times the RMS value.

Hence, the capacitor you use across the AC line must be able to accommodate 547.66 volts in order to not be damaged. A capacitor with a 600-volt rating may last indefinitely in this application, but it is marginal at best. Play it safe by installing a capacitor with a 1000-volt or greater rating.

Electrolytic and Tantalum Capacitors

There are many kinds of high-capacitance units to choose from. All of them are fine for use in power-supply filters and in decoupling circuits that require a low impedance voltage-supply line.

However, in those applications where minimum X_L is necessary, you will be wise to install tantalum capacitors. They are compact devices that have minimal internal inductance. In fact, they work

COMPUTERIZE YOUR SHACK

Control up to eight digital radios simultaneously from your MS-DOS microcomputer! We offer a series of software/hardware packages that interface with most current synthesized rigs.

ICOM: IC-781, 765, 761, 751A, 735, 725, R71A, R7000, 271, 371, 471, 1271, 275, 375, 475, 575, CI-V

KENWOOD: TS-940, 440, 140, R-5000, 680, 711, 811

YAESU: FT-767, 757 GXII, 757 GX, 747, 9600, 736

JRC: NRD 525

COLLINS: 651 S1

Datacom couldn't be simpler. Knowledge of MS-DOS is not necessary — the installation program does it all! Datacom allows complete control of your rig from the keyboard.

A few of its many features:

- Adds scan function to radios that don't allow this from front panel.
- Adds frequency and associated info memory limited only by disk storage.
- Tabular screen display of all the channels stored in memory, along with a full description of each including: mode (LSB, USB, FM, etc.), eight character alphanumeric description, signal bandwidth.
- Full featured logging utility.
- Able to automatically log hits while sweeping.
- Color coded program for ease of use (will run on a monochrome system).
- Menus for amateur, AM-FM broadcast, television broadcast, S/W, aviation, marine, with most popular frequencies stored.

Call or Write today for more information

AVAILABLE FOR IBM PC, XT, AT, 80386 256K RAM
1 SERIAL PORT AND 1 FLOPPY MINIMUM

PROGRAM WITH INITIAL LIBRARIES.....	99.95
RS-232 TO TTL INTERFACE ONLY (NEEDED IF DON'T HAVE MANUFACTURERS INTERFACE)	
EXTERNAL INTERFACE ALLOWS 4 RADIOS (NOW WITH SQUELCH DETECT CIRCUITRY).....	129.95
INTERNAL PC INTERFACE W/ SERIAL & 1 RADIO PORT.....	129.95
SPECTRUM ANALYZER MODULE.....	(CALL FOR PRICE)
COMPLETE SYSTEMS INCL. RADIO, INTERFACE, COMPUTER, AVAILABLE.....	(CALL FOR PRICE)

DATAKOM, INT. 8081 W. 21ST LANE • HIALEAH, FL 33016
AREA CODE (305) 822-6028

well as coupling and bypass capacitors in RF circuits up to approximately 10 MHz or so. The small size of tantalum capacitors makes them ideal for use in compact PC-board modules.

The only limitation I can think of is their relatively low voltage rating. They are intended primarily for circuits that have an operating voltage of 28 or less, DC. Most suppliers do not list tantalums that have maximum surge-voltage ratings in excess of 35.

Some Final Thoughts

Try in all instances to avoid unwanted X_L . At the higher frequencies it is not uncommon for, say, a 100-pF disc capacitor to exhibit a capacitance of 30 or 40 pF. This is because the X_L that is present cancels part of the effective capacitance of the component. The longer the capacitor leads, the worse the situation.

Always be mindful of the voltage rating of the capacitor you use. Allow plenty of leeway in the rating in order to prevent damage to the capacitor.

Don't rely on the marked value of your capacitors if they are to be used in critical circuits. Check them with a calibrated digital capacitance meter. I have found many disc ceramics that were not close to having the marked value.

For example, a batch of 0.001 uF capacitors I recently bought showed capacitances between 680 and 830 pF. In other situations, I have bought capacitors that had values well above the marked amount (0.02 uF units that ranged from 0.28 to 0.31 uF!). I have observed, however, that most silver-mica and polystyrene capacitors are very close in value to that which is marked on them. Likewise for NPO disc ceramics.

