

6 June 1968

Materiel Test Procedure 6-2-514
Electronic Proving GroundU. S. ARMY TEST AND EVALUATION COMMAND
COMMON ENGINEERING TEST PROCEDURE

ELECTRICAL POWER REQUIREMENTS

1. OBJECTIVE

The objective of this Materiel Test Procedure is to determine the electrical power requirements of communications, surveillance and electronic materiel.

2. BACKGROUND

Although the various items in the above category are supplied with instruction manuals and specification plates which purport to detail their respective power requirements, under certain conditions, these power requirements may vary to the extent that the item's capability to function efficiently is severely restricted. Engineering tests such as those contained herein, when performed under such conditions, allow the user to investigate the degree of disparity between stated power requirements and power requirements measured empirically. In addition, such tests allow the user to determine the impact of power requirement variations on the performance of the test item. This data, when analyzed properly, provides an important indication of the test item's overall effectiveness as a single unit or as an integral part of a system, functioning under actual field conditions.

3. REQUIRED EQUIPMENT

- a. Voltmeters
- b. Ammeters
- c. Wattmeters
- d. Frequency meters
- e. Oscilloscope with camera
- f. Strip chart recorder

4. REFERENCES

- A. Wind, Moe, Handbook of Electronic Measurements, Vol. 1, Polytechnic Institute of Brooklyn, 1956.
- B. Kinnard, Issac F., Applied Electrical Measurements, John Wiley & Sons, Inc., New York, 1956.
- C. Golding, E.W., Electrical Measurements and Measuring Instruments, 4th Edition, Sir Isaac Pitman & Sons, Ltd., London, England.
- D. Knowlton, A.E., Standard Handbook for Electrical Engineers, Ninth Edition, McGraw-Hill Book Company, New York, New York, 1957.
- E. TM-11-664, Theory and Use of Electronic Test Equipment.
- F. TM 11-663, Electronic Power Supplies.
- G. MTP 6-1-003, Determination of Sample Size

2004 02 04 006

5 June 1968

5. SCOPE

5.1 SUMMARY

This Materiel Test Procedure describes the following engineering subtests required to determine the electrical power requirements of given electronic materiel:

a. Warm-up Requirements Subtest - The objective of this subtest is to determine the test item's electrical power requirements during its warm-up period.

b. Range of Power Requirements Subtest - The objective of this subtest is to determine the test item's power requirements as the test item is brought from standby or minimum load operation to peak loading conditions.

c. Frequency Variation Subtest - The objective of this subtest is to measure the test item's performance in the presence of frequency variations in the primary power supply.

d. Voltage Variation Subtest - The objective of this subtest is to measure the effects of variations in the power supply voltage level upon the test items performance. Performance of test item low and high voltage protection devices will also be investigated as a part of this test.

5.2 LIMITATIONS

a. Testing of power sources and power transmission lines are considered only with respect to their error contributions to the overall measurement. In general, power requirements of the test item will be measured only at the point where the power transmission cable is mated to the test item.

b. Apparent or available power is not a primary consideration although it may be derived in some cases from test data.

c. Reactive power (power available but not by the test item) is not a primary consideration.

6. PROCEDURES

6.1 PREPARATION FOR TEST

6.1.1 Pretesting Procedures

a. Prior to testing it will be necessary to establish a "plane of reference" such that the portion of the system under test on the power source side of the plane is designated "power source and transmission lines" and the portion of the power sink side of the plane is approximately designated as the test item. The plane of reference shall be located at a conveniently accessible point in close proximity to the point at which the power transmission line is mated to the test item. All measurement instrumentation unless otherwise indicated in the individual test procedures shall be connected to the power sink side of the plane of reference.

600 40 20 400

6 June 1968

b. All laboratory power supplies employed in the test procedures shall be examined prior to testing and their electrical characteristics determined and cataloged. Specifically, DC power supplied shall be tested for ripple content and AC power supplies checked for harmonic distortion.

c. In order to monitor the test item's performance in the presence of input power and/or frequency variations a convenient operating parameter of the test item shall be selected to serve as a standard reference indicator. Examples of standard reference indicators would be receiver sensitivity, transmitter output, gain, frequency response, dynamic response, etc. When the standard reference indicator has been selected, the test item shall be operated such that it draws rated power and the level of the indicator noted for future reference.

d. Personnel responsible for conducting the test should ensure that applicable instructions and design specifications are available.

e. Operating instructions for test instruments, to be used in the conduct of the test, should be obtained and available to test personnel.

f. A test log book or folder should be prepared and utilized to record data during tests.

g. Ensure that all test instruments have been calibrated to within desired tolerances and possess a current calibration tag.

h. Brief test personnel on the purpose of the test, responsibilities of each, functions to be performed during testing and the degree of accuracy expected.

6.1.2 Preparation of Test Log

Data to be recorded in the test log prior to testing shall include but not be limited to the following:

- a. Name of the particular test
- b. Nomenclature and serial number of test item
- c. Identification of plane of reference
- d. Standard reference indicator description
- e. Standard reference indicator level
- f. Power supply electrical characteristics
- g. Power supply nomenclature and serial number

6.2 TEST CONDUCT

NOTE: To produce data from which valid conclusions may be drawn, the test procedures outlined herein shall be subjected to repetition to simulate an equivalent number of units tested one time each. Size, shall be consulted prior to testing in order to ensure statistical validity of the resultant.

6.2.1 Warm-up Power Requirements Subtest

a. Ensure that the test item is turned off and has been in the off position for a period of time sufficient for it to reach the ambient temperature.

b. Connect the test item to a power source capable of supplying the nominal voltage (and frequency, where applicable) stated by the developer of the test item.

c. Connect the test instruments to the test item as indicated in Figures 1, 2, or 3 according to the type of power source required.

d. Turn on and operate the test item such that it instantaneously requires rated power from the power source and continuously record data from all instrumentation until data indicates that a steady state condition has been achieved or the test item indicates a standard reference level, whichever requires the longer time.

6.2.2 Range of Power Requirements Subtest

The range of the test item's power requirements is empirically determined by the following test method:

a. Connect the test item to a power source capable of supplying the nominal voltage (and frequency, where applicable) as stated by the developer of the test item.

b. Connect the test instrumentation to the test item as indicated in Figures 1, 2, or 3 according to the power source type.

c. After having allowed sufficient time for the test item to warm-up, adjust the test item's controls such that it consumes a minimum amount of power from the power source and activate the recording instruments.

d. Successively adjust the test item's controls to increase the power supply loading until the test item is operating at peak load conditions. Note and record the test item's control positions in the margin of the chart recording paper in order to be able to correlate power requirements with test item usage.

6.2.3 Frequency Variation Subtest

The effect of frequency variations in the primary power supply on the power consumed by and performance of the test item shall be investigated in accordance with the following procedure.

a. Connect the test item to a variable frequency power supply, adjust to deliver the nominal voltage and frequency stated by the developer of the test item.

b. Connect the test instrumentation as indicated by Figure 2 or 3 (whichever is applicable).

c. While maintaining a constant input voltage level, vary the power supply frequency in incremental steps from 45 to 65 Hz for 60 Hz power requirements or 380 to 420 Hz for 400 Hz power requirements and record the corresponding standard reference indicator levels. Obtain a sufficient number of points to be able to plot a smooth curve of input frequency versus standard reference indicator level.

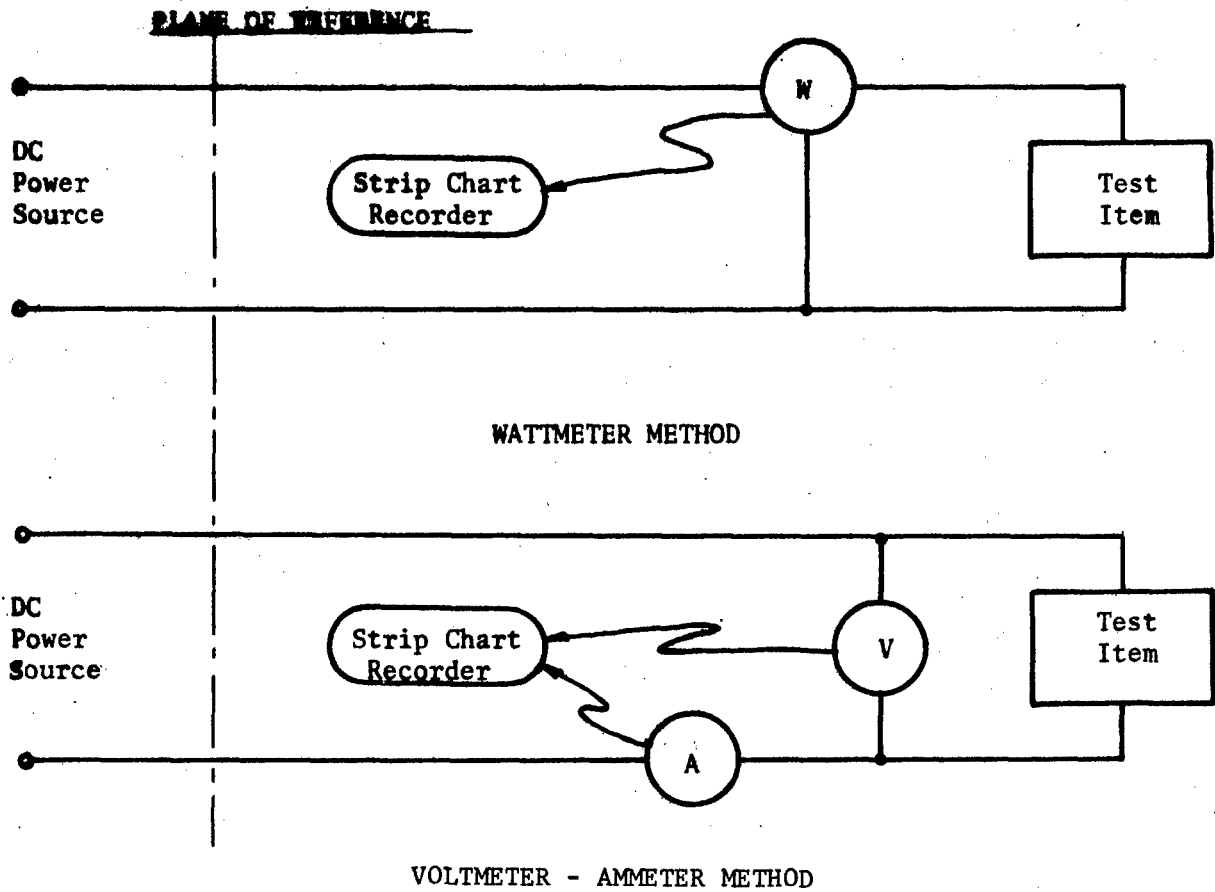

Figure 1. Block Diagram of Possible Equipment Setups for Monitoring DC Power Requirements.

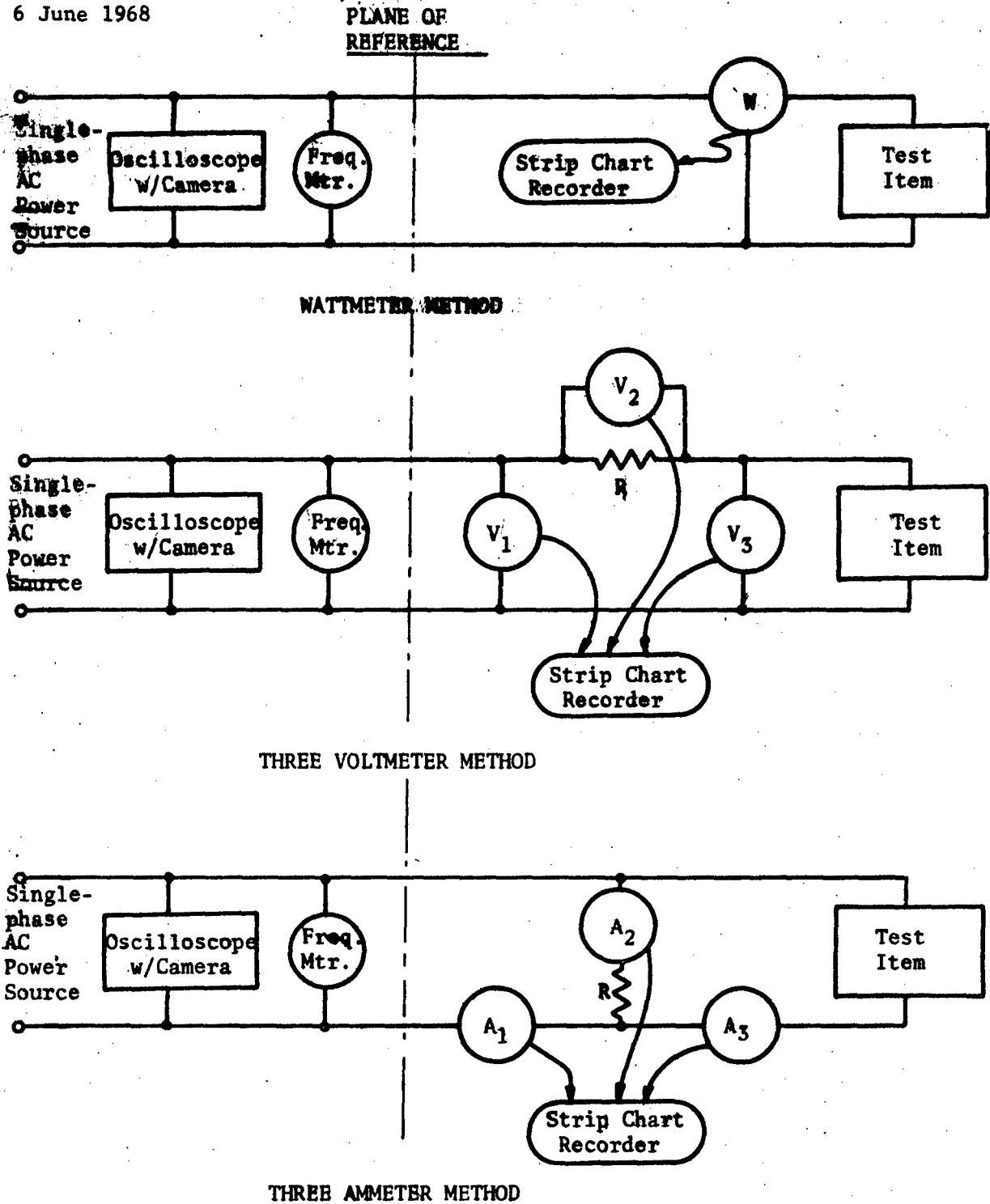

FIGURE 2. Block Diagram of Possible Equipment Setups for Monitoring Single-phase AC Power Requirements.

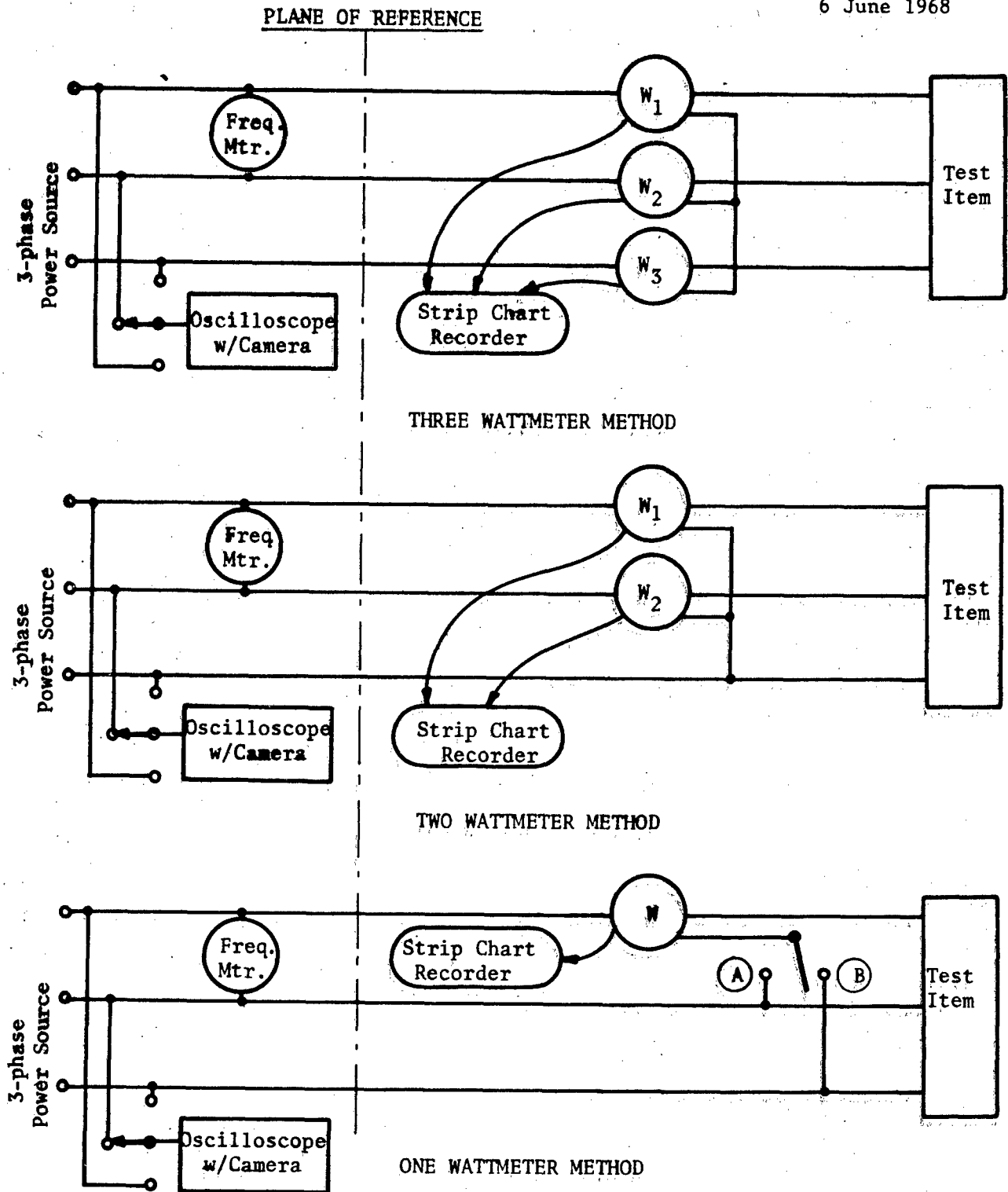

FIGURE 3. Block Diagram of Possible Equipment Setups for Monitoring Three Phase Power Requirements.

6.2.4 Voltage Variations Subtest

The effects of variations in the power supply voltage level upon the test item's performance will be determined by the following test procedure:

- a. Connect the test item to a variable voltage power supply adjusted to deliver the nominal rated voltage (and frequency, where applicable) stated by the developer of the test item.
- b. Connect a voltmeter across the power source side of the plane of reference and provide power monitoring instrumentation as shown in Figures 1, 2, or 3 as applicable.
- c. After having allowed sufficient warm-up time, decrease the power supply voltage in small decrements and monitor the corresponding power and standard reference indicator levels. Cease testing when the standard reference indicator level falls outside of stated tolerances or fails to respond.
- d. Increase the power supply voltage from 0 volts and note the voltage at which the test item's standard reference indicator initially responds and finally achieves the standard reference level.
- e. Increase the power supply voltage from nominal rated voltage in incremental steps and monitor the corresponding power and standard reference indicator levels. Cease testing when the standard reference indicator level falls outside of stated tolerances or the test item's overvoltage protection devices operate.

6.3 TEST DATA

6.3.1 Common Subtest Data

- a. Record remarks and observations which would aid in subsequent analysis of the test data.
- b. Record the instrumentation or measurement system mean error or stated accuracy.
- c. Record the test item sample size (number of measurement repetitions).

6.3.2 Warm-up Time Subtest Data

- a. Record the ambient temperature in degrees centigrade.
- b. Record the input power, as a function of time, in watts.
- c. Record the input voltage wave form.
- d. Record the power source frequency, as a function of time, in hertz.

6.3.3 Range of Power Requirements Subtest Data

- a. Record the input power, as a function of control position, in watts.
- b. Record the input frequency, as a function of control position, in hertz. (where applicable).

c. Record the input waveform as a function of control position (where applicable).

6.3.4 Frequency Variations Subtest Data

- frequency.
- a. Record the standard reference indicator level as a function of input frequency.
 - b. Record the input power, as a function of frequency, in watts.
 - c. Record the input voltage waveform at each frequency.
 - d. Record the ambient temperature in degrees centigrade.

6.3.5 Voltage Variations Subtest Data

- voltage.
- a. Record the standard reference indicator level as a function of voltage.
 - b. Record the input power, as a function of input voltage, in watts.
 - c. Record the ambient temperature in degrees centigrade.
 - d. Record the input voltage waveform and frequency.

6.4 DATA REDUCTION AND PRESENTATION

6.4.1 Common Subtest Data Reduction

- a. Correct power measurements for power dissipated in the measurement system.
- b. Compute mean values and standard deviations of measurements subjected to repetition.
- c. Organize data for presentation in tabular or graphical form.
- d. Mark all test data for identification and correlate and group according to subtest title.
- e. Prepare a written report to accompany the tabular test data and emphasize test results, conclusions and recommendations drawn from analysis of the test findings.

6.4.2 Warm-up Power Requirements Subtest Data Reduction and Presentation

6.4.2.1 Data Reduction

Reduce data in this subtest as indicated in 6.4.1 a through e.

6.4.2.2 Data Presentation

- a. Present data in both tabular and graphic form with separate presentations of the data listed in 6.3.2 b, c, & d made for each ambient temperature at which measurements were taken.
- b. Presentation of data in graphic form shall be accomplished as follows:

- 1) Plot input power in watts against time in seconds
- 2) Plot power source frequency in hertz against time in seconds

6.4.3 Range of Power Requirements Subtest Data Reduction and Presentation

Reduce data in this subtest as indicated in 6.4.1 a through e

6.4.3.2 Data Presentation

- a. Present data in both tabular and graphic form with the test item control position plotted as the dependent variable.
- b. Presentation of data in graphic form shall be accomplished as follows:

- 1) Plot input power in watts against control position
- 2) Plot input frequency in hertz against control position

c. Present the test item control position at which rated power was achieved.

d. Present the difference between rated power and measured power under standard operating conditions and explain the discrepancy.

e. Present the ratio of maximum load demand to rated load demand as the test items demand factor.

6.4.4 Frequency Variations Subtest Data Reduction and Presentation

6.4.4.1 Data Reduction

Reduce data in this subtest as indicated in 6.4.1 a through e.

6.4.4.2 Data Presentation

a. Present data in both tabular and graphic form with separate presentations of data listed in 6.3.4 a & b, made for each ambient temperature at which measurements were taken.

b. Presentation of data in graphic form shall be accomplished as follows:

- 1) Plot standard reference indicator level against input frequency
- 2) Plot input power against input frequency

6.4.5 Voltage Variation Subtest Data Reduction and Presentation

6.4.5.1 Data Reduction

Reduce data in this subtest as indicated in 6.4.1 a through e.

6.4.5.2 Data Presentation

a. Present data in both tabular and graphic form with separate presentations of data listed in 6.3.5 a & b made for each ambient temperature at which measurements were taken.

b. Presentation of data in graphic form shall be accomplished as follows:

- 1) Plot standard reference indicator level against input voltage
- 2) Plot input power against input voltage

c. Present the point at which the standard reference level indicator level fell outside the stated tolerance or failed to respond as the input voltage was decreased.

d. Present the point at which the standard reference indicator initially responded and finally achieved the standard reference level as the input voltage was increased from zero volts.

e. Present the point at which the standard reference indicator level fell outside the stated tolerance and the test item's overvoltage protection devices activated as the input voltage was increased.

f. Present voltage waveforms correlated with appropriate tabular and graphical presentations of input power as a function of input voltage.

NOTE: It is an implied condition that all measured values presented in either tabular or graphical form in 6.4 shall be mean values corrected for power dissipated in the measurement system. Additionally, it is implied that the standard deviation from the mean be indicated whenever mean values are shown.

APPENDIX A

ELECTRICAL POWER REQUIREMENTS

POWER MEASUREMENTS AT DC

Although wattmeters may be used to measure DC power, the latter is usually best determined by measuring separately two of the three quantities V, I, and R and by computing the power from the well known relationships:

$$P = \frac{V^2}{R} = I^2 R = VI$$

where V is the voltage across the terminals of the circuit, I the current in the circuit and R the circuit resistance.

If the voltage and current are measured simultaneously, corrections must generally be made for the power dissipated in the instrument (either ammeter or voltmeter) which is connected nearest the load. Usually the resistance of the voltmeter is known and it is then preferable to connect the voltmeter directly across the load and to measure the current into the parallel combination of the voltmeter and load. The load power is then given by:

$$P = VI - \frac{V^2}{R_v}$$

where V and I are the voltage and current readings respectively and R_v is the voltmeter resistance. When the ammeter is connected nearest the load the power is given by:

$$P = VI - I^2 R_a$$

where R_a represents the ammeter resistance. For either type of connection the power dissipated in the load is given by the product of voltage and current less the power dissipated in the meter nearest the load. Figure 1, illustrates the possible test equipment setups for measurement of DC power.

MEASUREMENT OF SINGLE PHASE AC POWER

A. Wattmeter Method

In Alternating current circuits the power at any instant is given by :

$$p = ei \quad \text{Where: } p = \text{instantaneous power}$$
$$e = \text{instantaneous voltage}$$
$$i = \text{instantaneous current}$$

Thus, if both the current and voltage waves are sinusoidal, the current lagging in phase by an angle ϕ , then

$$e = E \max \sin \omega t$$

and $i = I \max \sin (\omega t \phi)$

The instantaneous power p is therefore given by:

$$p = E \max I \max \sin \omega t \sin (\omega t - \phi)$$

The mean power P may therefore be shown as:

$$P = \frac{1}{2\pi} \int_0^{2\pi} E \max I \max \sin \omega t \sin (\omega t - \phi) dt$$

$$\text{Or } P = \frac{E \max I \max}{2} \cos \phi$$

Therefore $P = EI \cos \phi$ where E and I are rms values of voltage and current.

The fact that the power factor ($\cos \phi$) is involved in the expression for the power means that a wattmeter must be used instead of merely an ammeter and voltmeter, since the latter method takes no account of power factor. Of the three possible methods for measuring AC power shown in Figure 2, the wattmeter method is most expeditious.

B. Three - Voltmeter Method

It is possible to measure the power required by a single phase AC load without a wattmeter by using three voltmeters in conjunction with a non-inductive resistance as shown in Figure 2. The simultaneous readings of the three voltmeters and resistance value of the non-inductive resistance are inserted into the following formula to determine the power required by the load:

$$\text{Power in load} = \frac{V_1^2 - V_2^2 - V_3^2}{2R}$$

If desired, the power factor is also calculated by the formula:

$$\cos \phi = \frac{V_1^2 - V_2^2 - V_3^2}{2V_2 V_3}$$

Assumptions made in deriving the above relationships are that the current in the resistance R is the same as the load current, and that the resistance is entirely non-inductive.

C. Three- Ammeter Method

The three ammeter method of measuring single phase AC power is somewhat similar to the above. The necessary test equipment connections are shown in Figure 2. The load power may be calculated from a knowledge of the current measured by the ammeters and the resistance value of the non-inductive resistor by use of the formula,

$$\text{Power in load} = \frac{(I_1^2 - I_2^2 - I_3^2)R}{2}$$

$$\text{Also Power factor } 5 \cos \phi = \frac{(I_1^2 - I_2^2 - I_3^2)R}{2I_2 I_3}$$

MEASUREMENT OF THREE PHASE POWER

A. Three Wattmeter Method

The test instrumentation connections for the three wattmeter method of measuring three phase power are shown in Figure 3. The sum of the simultaneous readings of the wattmeters will give the mean value of the total power required by the test item.

B. Two Wattmeter Method

This is the commonest method of measuring three - phase power. It is particularly useful when the load is unbalanced. The test instrumentation connections for the measurement are shown in Figure 3. If W_1 and W_2 are the two wattmeter readings, $W_1 + W_2$ gives the total power required by the test item, and

$$\tan \phi = \frac{\sqrt{3} (W_2 - W_1)}{W_1 + W_2}$$

From which ϕ and the power factor $\cos \phi$ of the load may be found.

C. One Wattmeter Method

This method can be used only when the load is balanced. The measurement setup is shown in Figure 3. As in the above method, the sum of the two wattmeter readings as obtained from switch positions A and B is the total power delivered to the test item. In the same way the angle ϕ is given by:

$$\tan \phi = \frac{\sqrt{3} (W_2 - W_1)}{W_1 + W_2}$$

and the power factor $\cos \phi$ is given by:

$$\cos \phi = \frac{1}{\sqrt{1 + \frac{3(W_2 - W_1)^2}{(W_1 + W_2)^2}}}$$