

HAM TIPS



A PUBLICATION OF THE RCA TUBE DIVISION

Vol. XVI, No. 2

©1956, Radio Corporation of America

July-August, 1956

VERSATILE MODULATOR

by Peter Koustas, W2SGR

RCA Tube Division, Harrison, N. J.



The modulator described in this article can furnish any audio power between 25 and 100 watts and, therefore, can modulate 100% any rf input power up to 200 watts. Maximum power output is determined primarily by the plate voltage applied to the modulator tubes. No circuit changes are necessary when the power output level is changed other than in the connections to the proper taps on the modulation transformer.

The input circuit, which will accommodate any type of microphone, utilizes a transistor because of its low power consumption. The stability and low noise factor of the RCA-2N104 made it a logical choice for this application.

Circuit Description

A schematic diagram of the modulator is shown in Figure 1.

The transistor circuit given here is straightforward and not at all critical. The RCA-2N104 is a germanium alloy-junction transistor of the p-n-p type intended especially for small-signal audio applications. It is shown connected here in a common-emitter, base-input circuit. This method of transistor operation is analagous to common-cathode operation of a vacuum tube triode — with the base, emitter, and collector of the transistor corresponding to the grid, cathode, and plate, respectively, of the vacuum tube.

However, unlike the vacuum tube, which has a high input impedance at audio frequencies, the input impedance of the 2N104 in the circuit shown is approximately 1,000 ohms. Thus, low-impedance microphones (e.g.: carbon or dynamic types) may be used in this circuit without matching transformers. Crystal microphones, and other high-impedance types, do require a matching transformer in this circuit and one has been provided (T_1).

The RCA-12AT7 is a twin triode with two identical sections, each having a μ of 60. One section is used to provide a second stage of voltage gain; the other serves as the driver stage for the modulator tubes. In order to take advantage of the full gain afforded by the transistor, an impedance-matching, 3-to-1 step-up transformer is used between it and the input to the second stage. Modulation level is controlled by a 250,000-ohm potentiometer in the grid circuit of the first section of the 12AT7. Resistance coupling is used between the second and third stages of the modulator. Decoupling between stages is provided by R_{16} and C_9 . Driver requirements are very modest, since no power is required to drive the modulator to full output. The second section of the 12AT7 develops adequate drive with no difficulty.

The outstanding features which make the RCA-6146 such a proven performer in rf service are the very reasons this versatile tube was chosen for the output stage of this modulator: high perveance and high power sensitivity. The high perveance of the 6146 allows this modulator to operate efficiently at low power levels with relatively low plate voltage. The high power sensitivity of the 6146 en-

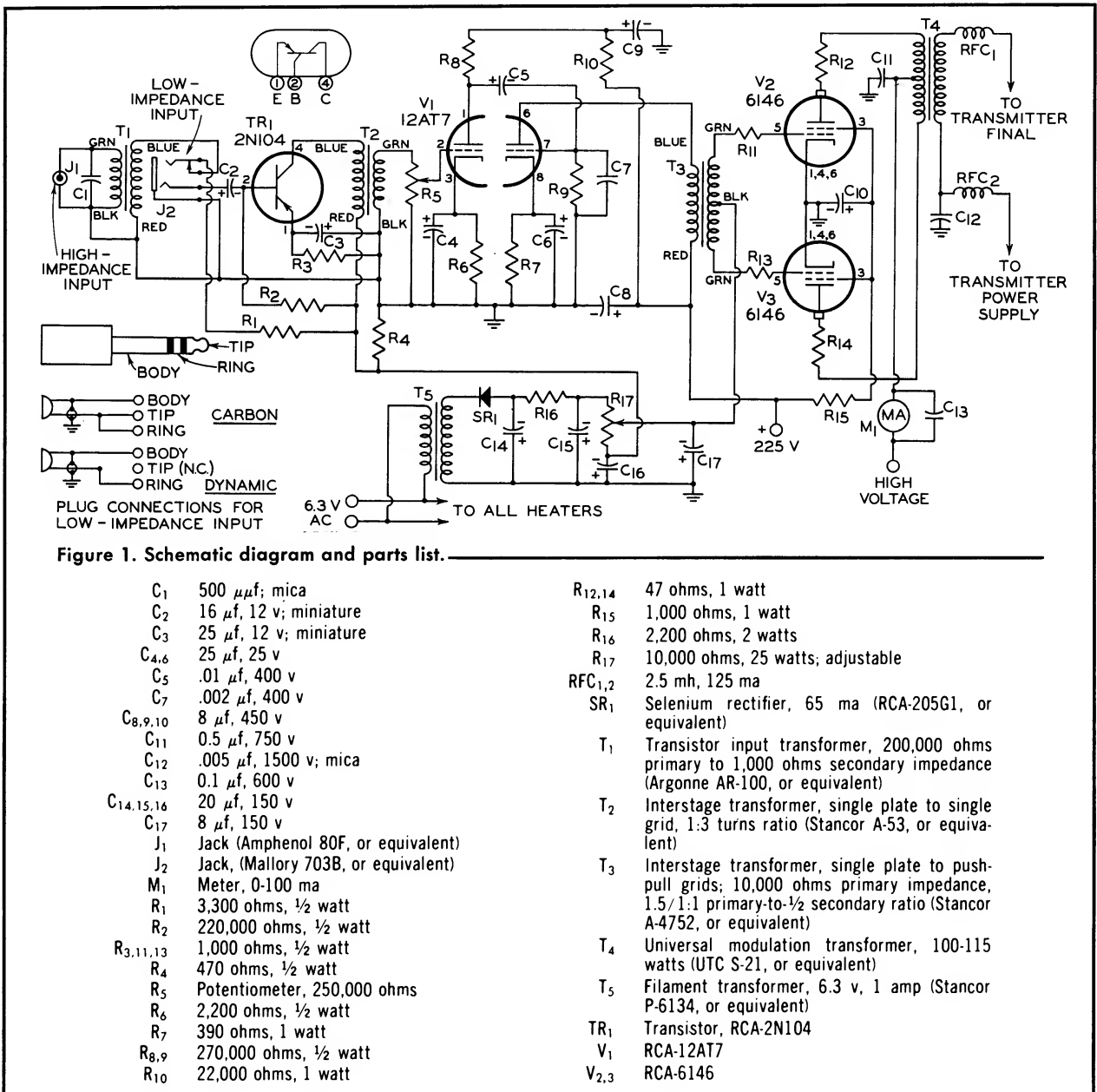

ables this modulator to deliver full power output with negligible power required from the driver stage.

The 6146's are operated class AB₁ for all power levels up to a maximum of 100 watts. A driver transformer (T₄) which has a tapped primary is used to provide push-pull signal voltage for the output tubes. If sufficient gain is not available for a particular microphone when using the 1.5-to-1 tap, an additional tap on the primary can provide a primary-to-1/2 secondary ratio of one-to-one. Two 1,000-ohm resistors in series with the grid leads of the 6146's are used for the suppression of parasitic oscillations. The 47-ohm resistors in each plate lead serve the same purpose. Although these resistors are seldom necessary in audio equipment, it is always good practice to include them as a precautionary measure.

The modulation transformer that was selected can handle the maximum power output of the modulator. (The difference in price between a 60-watt transformer and this 115-watt transformer is less than five dollars). To determine the correct *secondary* impedance it is only necessary to divide the input voltage to the transmitter final by the normal operating current. The correct *primary* impedance will range from 2,500 to 7,500 ohms, depending upon operating voltage. Figure 2(b) is a plot of the *minimum* primary impedance required to prevent tube damage, versus operating plate voltage.

Figure 2(a) is a plot of output power versus plate voltage applied to the 6146's. To determine the required modulator plate voltage for a particular transmitter, divide the input power to the final stage of the transmitter by

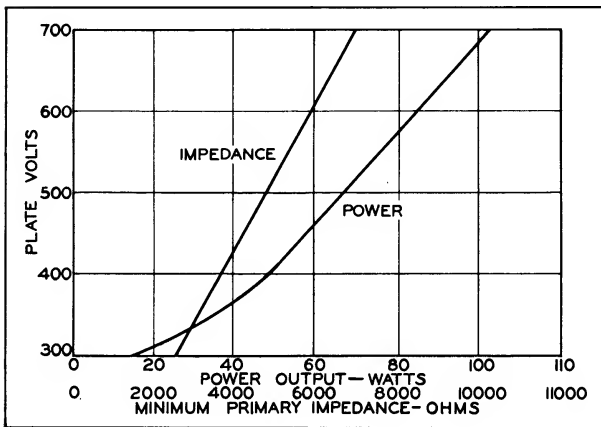

Figure 2. a) Power output vs plate voltage
b) Minimum primary impedance vs plate voltage

two, to get the audio power required for 100% modulation. Now find the minimum plate voltage required from Figure 2(a).

Higher plate voltages than those found from the above procedure may be used, and the modulation adjusted to the correct level by potentiometer R_5 . In any event, R_5 should be used for fine adjustment of modulation level.

A few words of caution should be injected at this point. *Never* operate any modulator without having a load connected to the output. The high impedance of an unloaded transformer secondary reflected into the primary will cause abnormally high signal voltages to be generated and will almost always cause the insulation of the transformer to be punctured. Also, to prevent damage to the 6146's, never operate this modulator with the primary impedance of the output transformer below the value given in Figure 2(b) for the plate voltage being used.

Construction

Construction of the modulator is not difficult and requires only normal care in wiring. It is built on a standard aluminum chassis 5x13x3 inches deep and mounted on a rack panel 5 $\frac{1}{4}$ x19 inches. This method of construction has two distinct advantages: a) a minimum of panel space is required; b) more complete shielding is obtained by utilizing the panel as the bottom cover of the chassis.

It is necessary to scrape the paint off the panel where the chassis comes in contact with it in order to insure a good rf bond between them.

The leads to the input jacks and gain control must be about five inches long, in order to allow assembly of the panel to the chassis after it is wired. It is therefore necessary to shield these leads to minimize any tendency

towards stray hum and feed-back pickup. For maximum effectiveness, all parasitic-suppressing resistors must be mounted right at the tube socket, and directly on the plate cap.

Power Supplies

Two external voltage supplies are required by the modulator.

The first supply is for the plates of the 6146's. The voltage rating of this supply will depend on the modulation power output desired, as determined from Figure 2(a). Zero-signal drain on this supply will be between 50 and 60 ma. At 750 v, maximum-signal drain will be approximately 230 ma. The power supply should be capable of supplying maximum-signal current with good regulation.

The second external power supply must deliver approximately 50 ma at 225 volts. This supply powers the 12AT7 and the screen grids of the 6146's. It should never be turned on until after the plate supply has been turned on. Preferably, the supplies should be so wired that the plate supply must be on before the low-voltage supply can be energized.

Operating voltage for the transistor and bias for the modulator tubes are supplied by an internal supply. *This supply should be turned on before either of the above supplies.* Again, sequential switching to ensure the proper order of energizing the supplies is to be preferred. Transformer T_5 is a 6.3-volt filament transformer connected in reverse to obtain 115 volts from the 6.3-volt heater supply. A selenium rectifier and RC filter (R_{16} , C_{14} , and C_{15}), provide a negative voltage supply of -100 volts. Resistors R_1 and R_2 form a voltage divider between ground and the junction of R_{17} and R_4 , which provides the 5 volts required to operate the transistor. Bias for the 6146's is adjusted by moving the tap of R_{17} to the appropriate point.

Operation

Other than usual precautions, there is no special procedure required to place the modulator in operation. The wiring should be thoroughly checked before any power is applied. With the tubes but not the transistor inserted, apply 6.3 v to the heater-voltage input terminals. The bias voltage at the grids of the 6146's should be set initially at maximum and then adjusted when all other voltages in the modulator are applied so that the zero-signal plate current as read on the meter is approximately 55 ma. Before insertion of the transistor, the voltage between ground and the junction of R_{17} and R_4 should be measured. If it is between 4.5 and 6 v, plug in

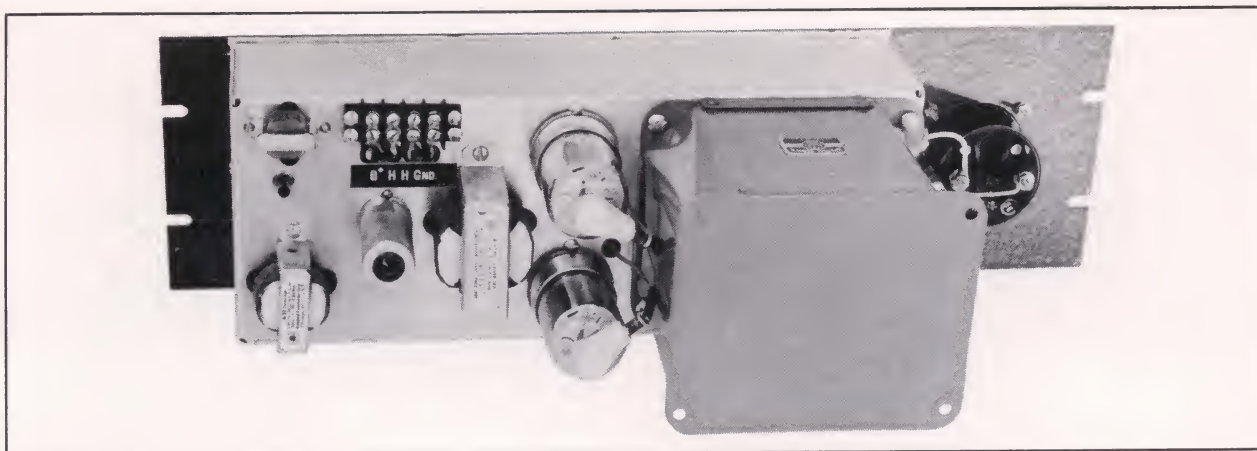

Figure 3. Rear view of modulator

the transistor. If the voltage at this point exceeds 6 v, a wiring mistake or a wrong value for R_4 may be the cause.

The modulator may be tested separately by using a resistor of the correct value as a load. The resistor used should have the same resistance as the impedance of the secondary taps to which it is connected and should be of sufficient power rating to withstand the

output of the modulator. Power output may be measured by applying an input signal and measuring the signal output voltage across the resistor. The output power will be $(\frac{E_{rms}}{R})^2$. Again, a warning: in no case should

R
the modulator be run without having a load connected to the secondary of the modulation transformer.

Devices and arrangements shown or described herein may use patents of RCA or others. Information contained herein is furnished without responsibility by RCA for its use and without prejudice to RCA's patent rights.



From your local
RCA distributor,
headquarters for
RCA receiving
and power tubes.

RCA HAM TIPS
is published by the
RCA Tube Division,
Harrison, N. J.
It is available free
of charge from
RCA Distributors

Harvey Slovik, Editor
Charles Howard, W2QIH
Technical Editor

WHEN MAILING
PLACE POSTAGE HERE

